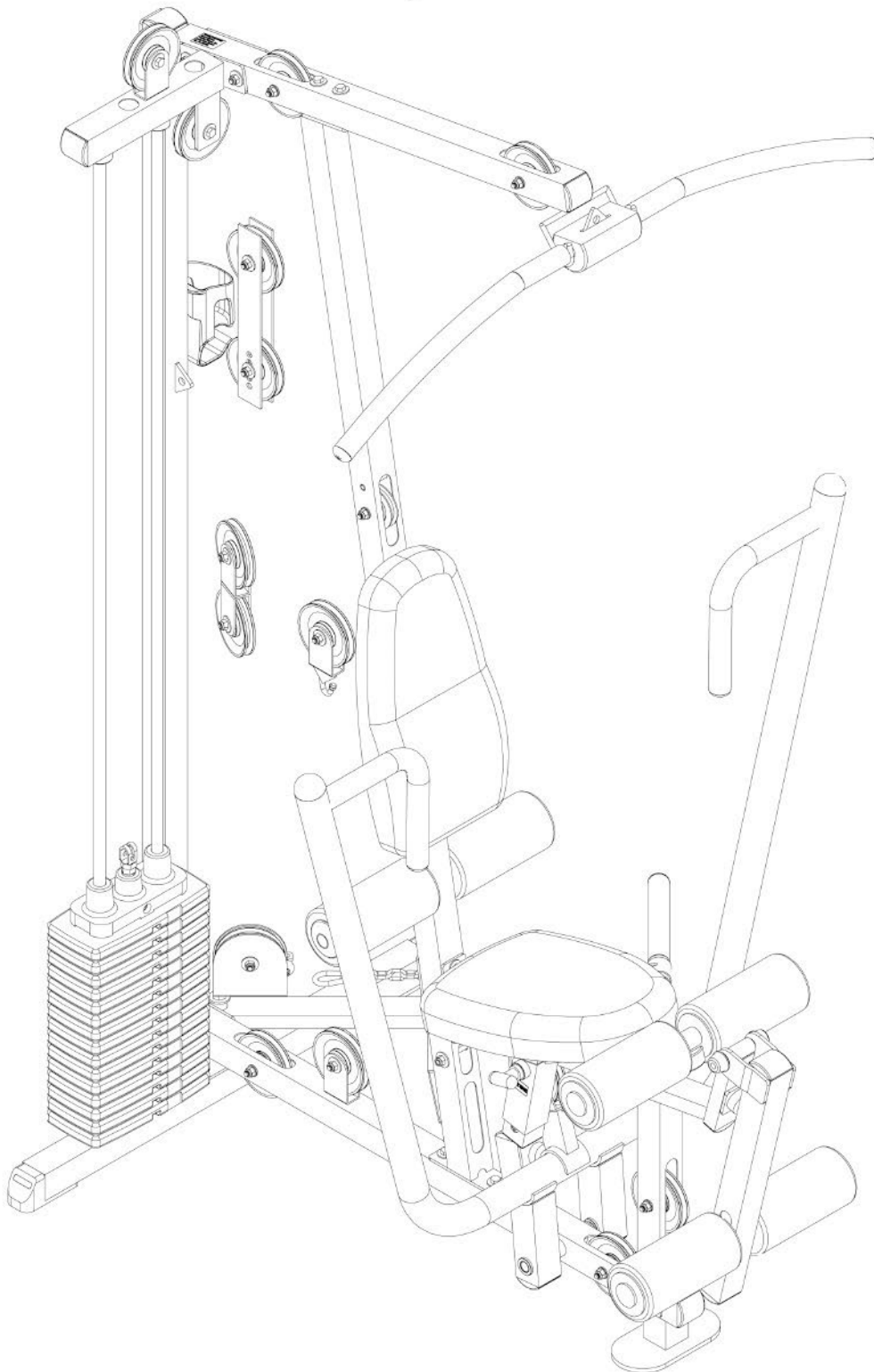


by *Body-Solid*<sup>®</sup>



Sport-Thieme GmbH  
Helmstedter Straße 40  
38368 Grasleben  
Telefon: +49 (0) 5357 181-81  
Fax: +49 (0) 5357 181 90  
info@sport-thieme.de  
www.sport-thieme.de

**A s s e m b l y**

**I n s t r u c t i o n s**

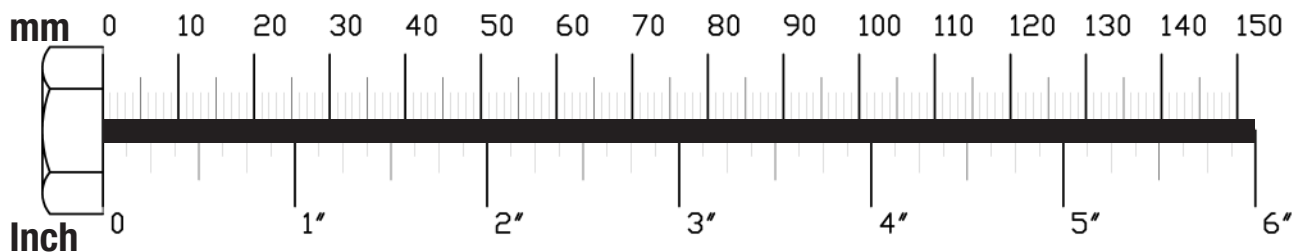
**STEP****1**

**Be careful to assemble all components in the sequence they are presented.**

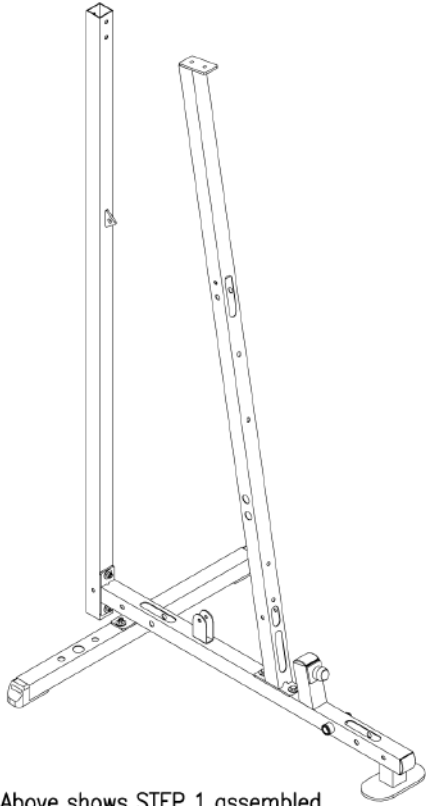
**NOTE:**

**Finger tighten all hardware in this step. Do Not wrench tighten until end of step 6.**

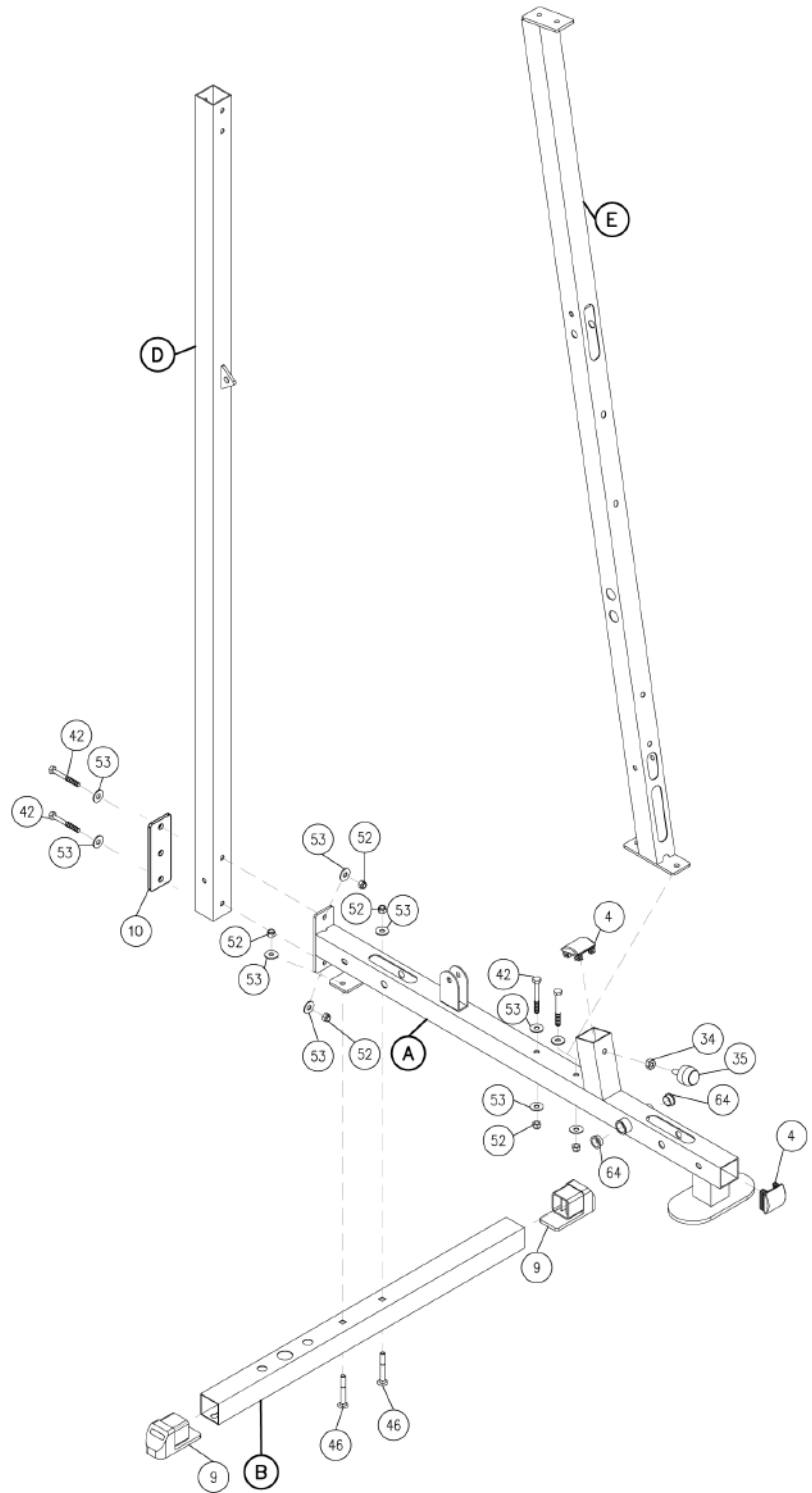
- A. Attach Main Base Frame (A) to Rear Base Frame (B) using:  
**Two 46 (3/8" x 2 3/4" carriage bolts)**  
**Two 53 (3/8" flat washer)**  
**Two 52 (3/8" nylon lock nut)**
- B. Attach 2 Foot Caps (9) to Rear Base Frame (B) as shown.
- C. Attach Vertical Support Pillar (D) and Flat Plate (10) to Main Base Frame (A) using:  
**Two 42 (3/8" x 2 3/4" hex head bolt)**  
**Four 53 (3/8" flat washer)**  
**Two 52 (3/8" nylon lock nut)**
- D. Attach Angled Support Pillar (E) to Main Base Frame (A) using:  
**Two 42 (3/8" x 2 3/4" hex head bolt)**  
**Four 53 (3/8" flat washer)**  
**Two 52 (3/8" nylon lock nut)**
- E. Attach Convex End Cap (3) to the front of the Main Base Frame (A).  
Attach Convex End Cap (3) to the top of the short pillar on top of the Main Base Frame (A).  
Attach Rubber Stop (35) with Jam Nut (34) to the short pillar on the Main Base Frame (A) as shown.



**STEP**  
**1**



Above shows STEP 1 assembled and completed.



**STEP****2****Be careful to assemble all components in the sequence they are presented.****NOTE:**

Finger tighten all hardware in this step. **Do Not** wrench tighten until end of step 6.

- A. Attach Top Frame (F) to Angled Support Pillar (E) using:

**Two 43 (3/8" x 2 1/2" hex head bolt)**

**Two 53 (3/8" flat washer)**

**Note:**

**Both bolts (43) go into the threaded housing inside the Angled Support Pillar (E)**

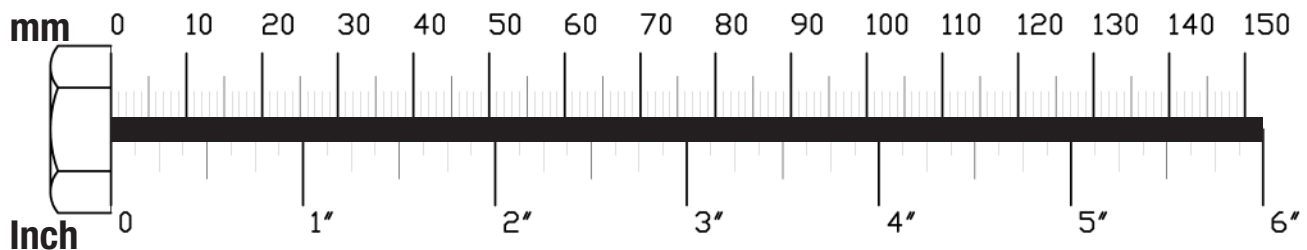
- B. Bolt Top Frame (F) and 2"x4" Plate (G) to Vertical Support Pillar (D) using:

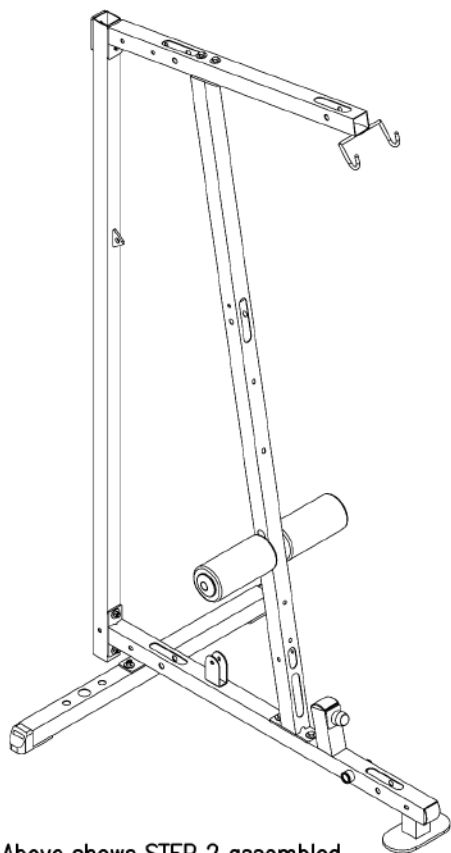
**Two 43 (3/8" x 2 1/2" hex head bolt)**

**Note:**

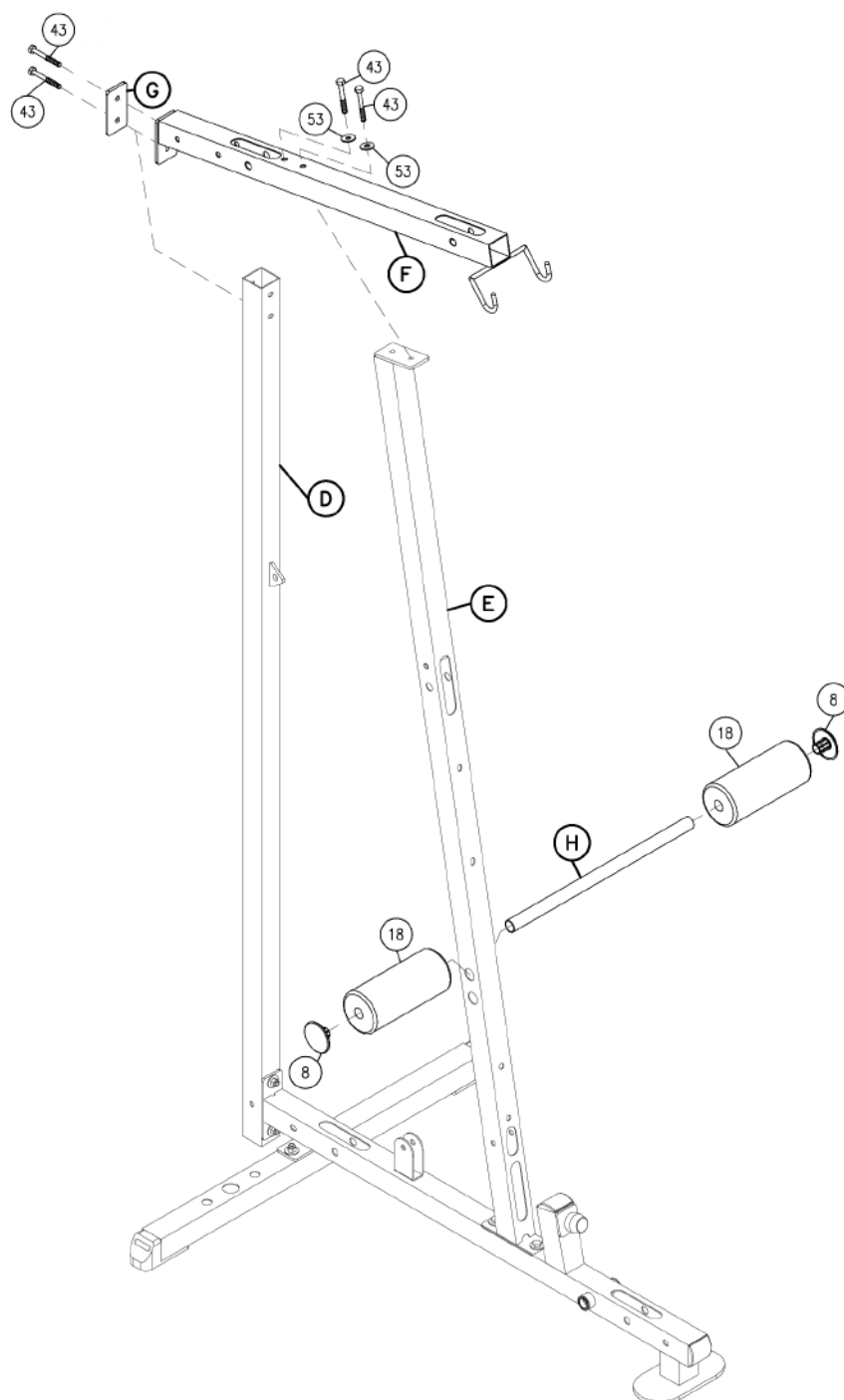
**Both bolts (43) go into the threaded housing inside the Vertical Support Pillar (D)**

- C. Put Foam Roller Bar (H) through Angled Support Pillar (E) and attach two Foam Rollers (18) with two 1" Roller End Cap (8) as shown. There are two possible openings to mount Foam Roller Bar (H) to Angled Support Pillar (D). If the main user of this gym is 6' tall (or more) mount in the top opening, for shorter people (under 6') mount in the lower opening. This piece is not inter-changeable, once these pads are installed they are permanent.





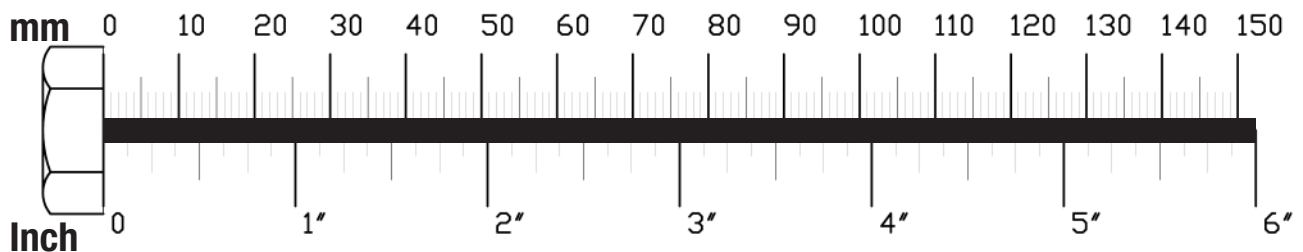
Above shows STEP 2 assembled and completed.

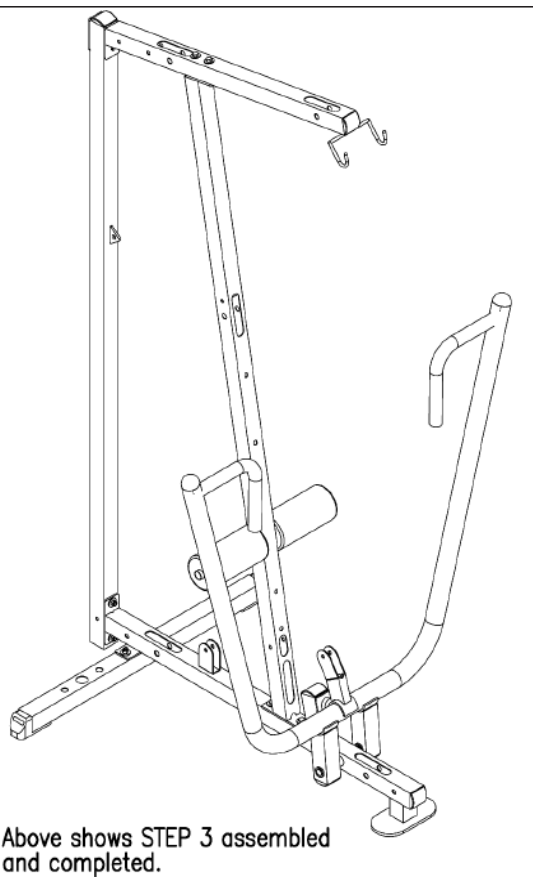


**STEP****3****Be careful to assemble all components in the sequence they are presented.****Note:**

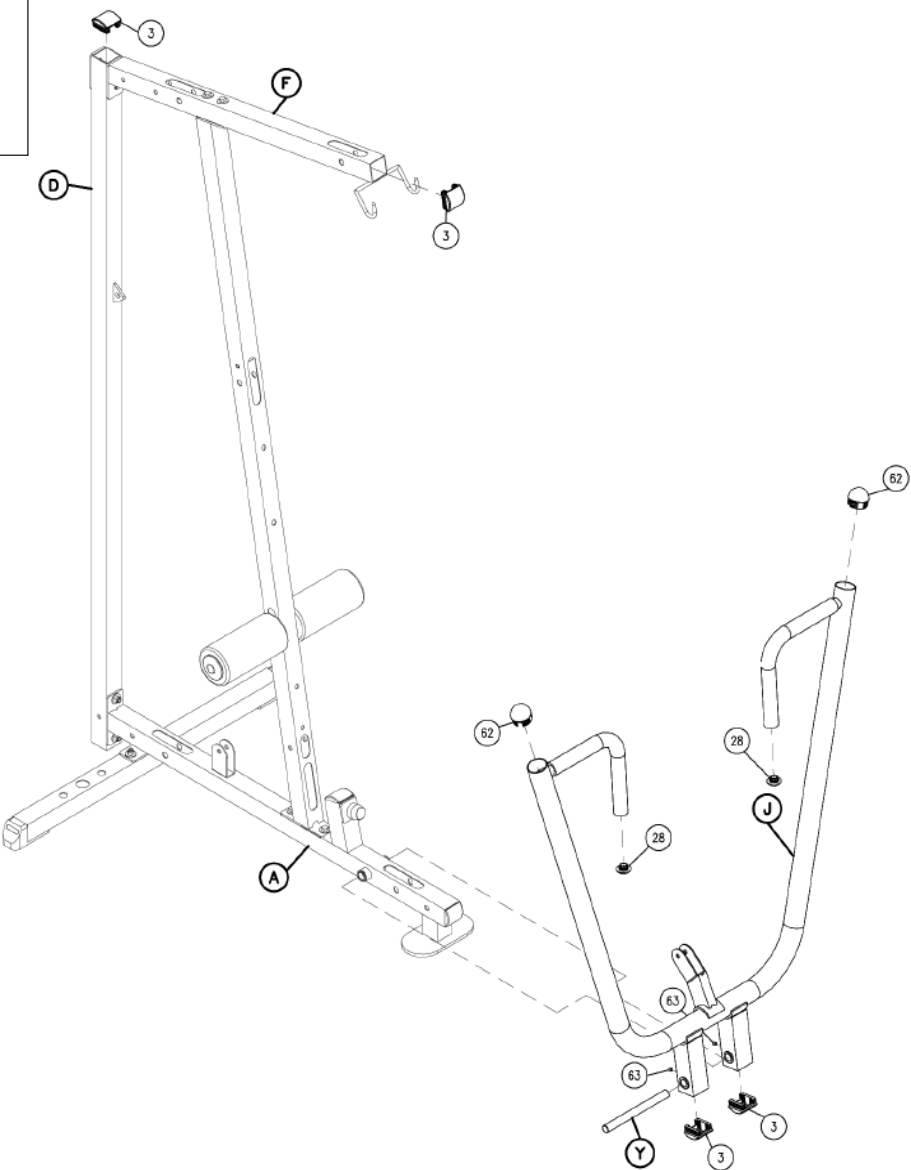
**Wrench tighten all hardware in this step only. Do not wrench tighten Frame bolts until after the installation of the weight stack in step 6.**

- A. Loosen Allen Head Bolts (63) at the bottom of Bench Press Frame (J).  
Slide out Pivot Shaft (Y) from inside of Bench Press Frame (J).
- B. Attach Bench Press Frame (J) to Main Base Frame (A) using the Pivot Shaft (Y) as shown.  
Retighten Allen Head Bolts (63) at the bottom of Bench Press Frame (J).
- C. Attach Convex End Caps (3) to the top of Vertical Support Pillar (D), front of Top Frame (F),  
and to the bottom of Bench Press Frame (J) as shown.





Above shows STEP 3 assembled and completed.



**STEP****4****Be careful to assemble all components in the sequence they are presented.****Note:**

**Finger tighten all hardware in this step (except where noted in step 4A).**

- A. Attach Low Pulley Bracket (K) to Foot Brace (L) using:  
**One 50 (1/2" nylon lock nut)**

**Note:**

**Wrench tighten the Nylon Lock Nut (50), but do not over-tighten. Over-tightening will restrict the Low Pulley Bracket (K) range of motion.**

- B. Attach Foot Brace (L) to Main Frame (A) using:  
**Two 42 (3/8" x 2 3/4" hex head bolt)**  
**Four 53 (3/8" flat washer)**  
**Two 52 (3/8" nylon lock nut)**

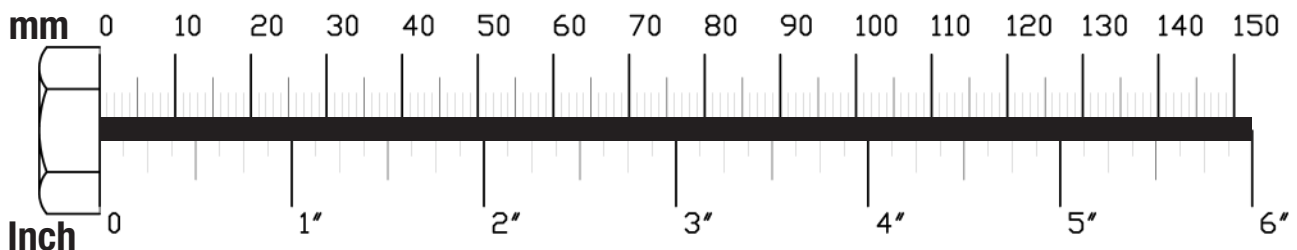
**Note:**

**Foot Brace (L) goes onto the right side of the gym (standing in front, facing the gym). Make sure holes for the weight stack are on the opposite side (left side).**

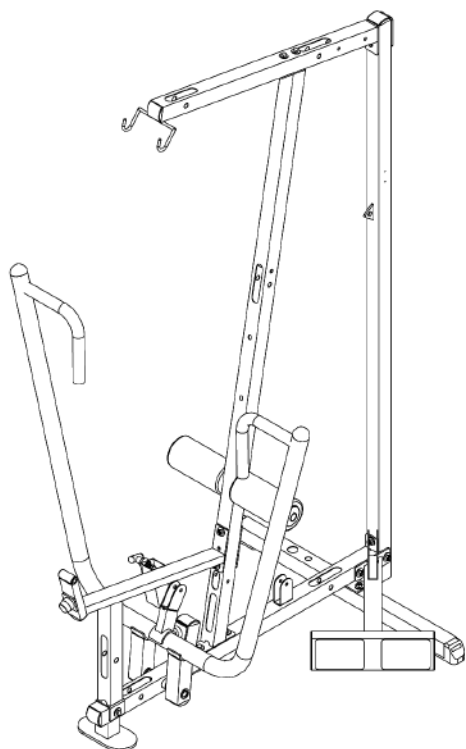
- C. Attach Seat Extension Frame (M) and 2"x5" Plate (N) to Angled Support Pillar (E) using:  
**Two 41 (3/8" x 3" hex head bolt)**  
**Two 52 (3/8" nylon lock nut)**

- D. Attach bottom of Seat Extension Frame (M) to Main Base Frame (A) using:  
**One 42 (3/8" x 2 3/4" hex head bolt)**  
**One 52 (3/8" nylon lock nut)**

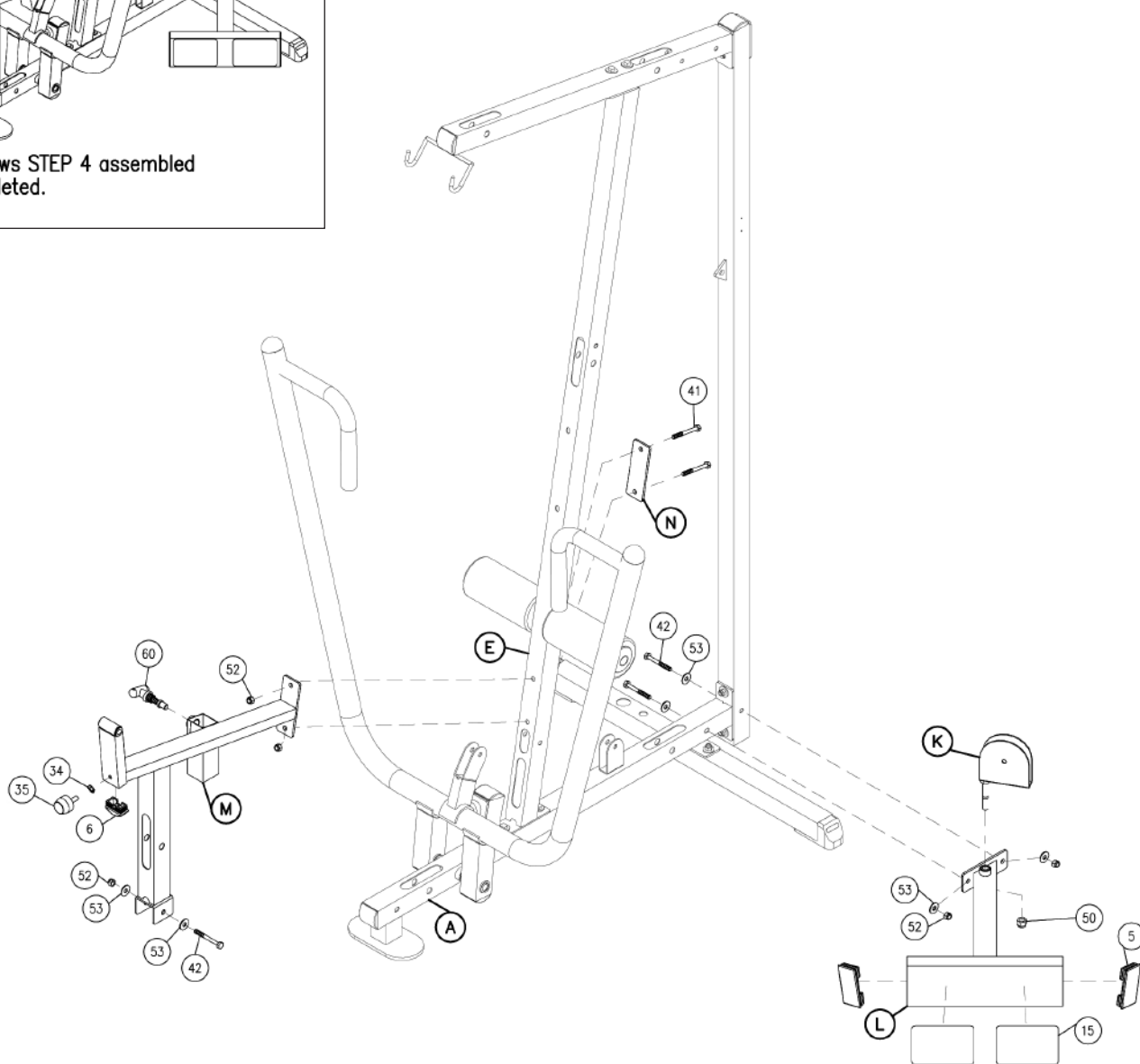
- E. Attach 2 Convex End Caps (5) and Grip Tape (15) to Foot Brace (L) as shown.  
Attach 1 Convex End Cap (6) and Rubber Pad (27) to Seat Extension Frame (M) as shown.  
Make sure Rubber Stop (35) and Jam Nut (34) is pre-installed into Seat Extension Frame (M).







Above shows STEP 4 assembled and completed.



**STEP****5****Be careful to assemble all components in the sequence they are presented.****Note:**

**Finger tighten all hardware in this step (except where noted in step 5B).**

- A. Put Foam Roller Bar (H) through Leg Frame (P) and attach 2 Foam Rollers (18) with 3" Plastic Washer (26) on the inside and 1" Roller End Cap (8) on the outside as shown.

**Note:**

**There are two possible holes to mount Foam Roller Bar (H) to Leg Frame (P). If the main user of this gym is 6' tall (or more) mount in the lower opening, for shorter people (under 6') mount in the top opening. This piece is not inter-changeable, once these pads are installed they are permanent.**

- B. Attach Leg Frame (P) to Seat Extension Frame (M) using:

**One 40 (1/2" x 3 1/4" hex head bolt)**

**Two 56 (1/2" round end cap washer)**

**One 50 (1/2" nylon lock nut)**

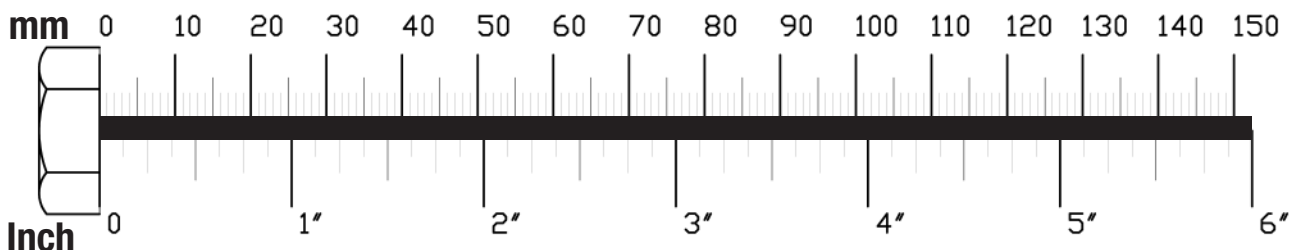
**Two 21 (1/2" bolt cover)**

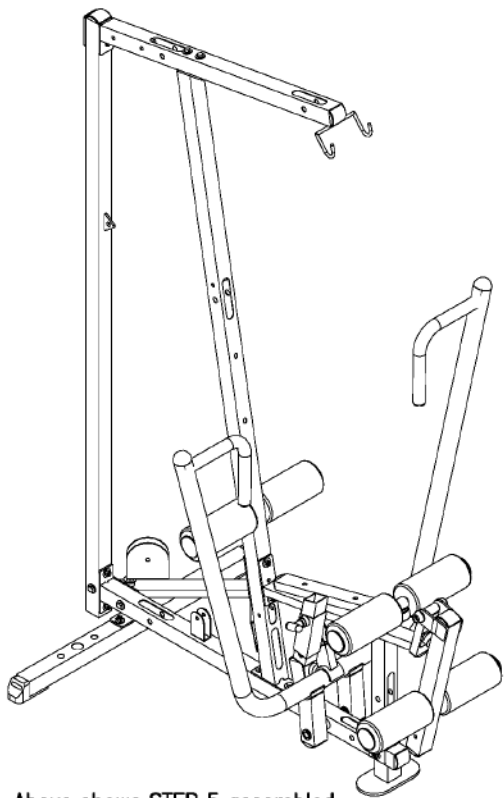
**Note:**

**Wrench tighten bolt (40) only. Leave all other bolts finger tight.**

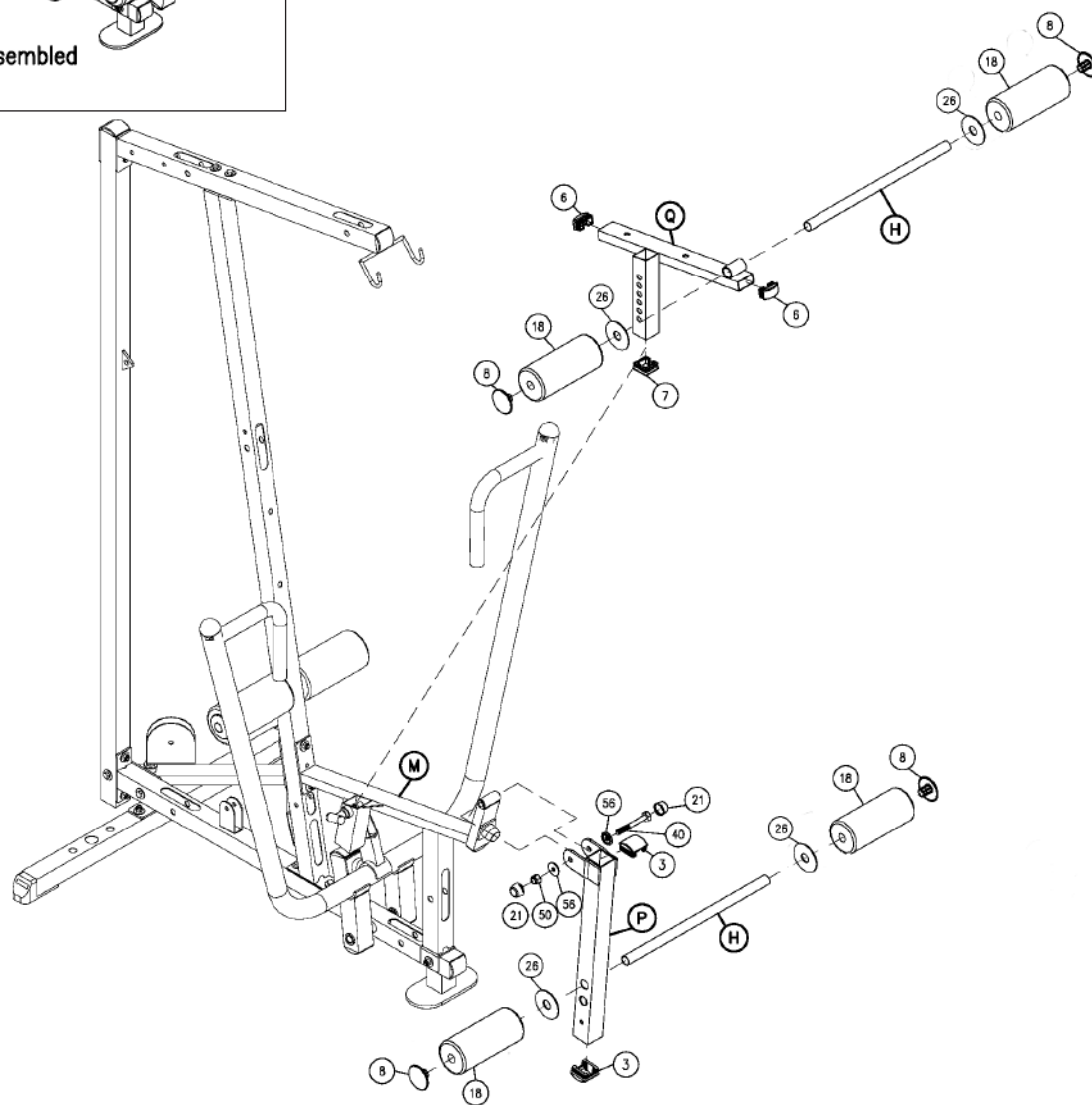
**Round End Cap Washers (56) hold Bolt Caps (21) in place.**

- C. Put Foam Roller Bar (H) through Seat Frame (Q) and attach 2 Foam Rollers (18) with 3" Plastic Washer (26) on the inside and 1" Roller End Cap (8) on the outside as shown.
- D. Put two Convex End Caps (3) into the top and bottom of Leg Frame (P). Put 1 3/4" x 1 3/4" End Cap (7) into the bottom of Seat Frame (Q). Slide Seat Frame (Q) into Seat Extension Frame (M), hold in place with Threaded Pop Pin (60). Attach two Convex End Caps (6) to the front and back of Seat Frame (Q) as shown.





Above shows STEP 5 assembled and completed.



**STEP****6****Be careful to assemble all components in the sequence they are presented.**

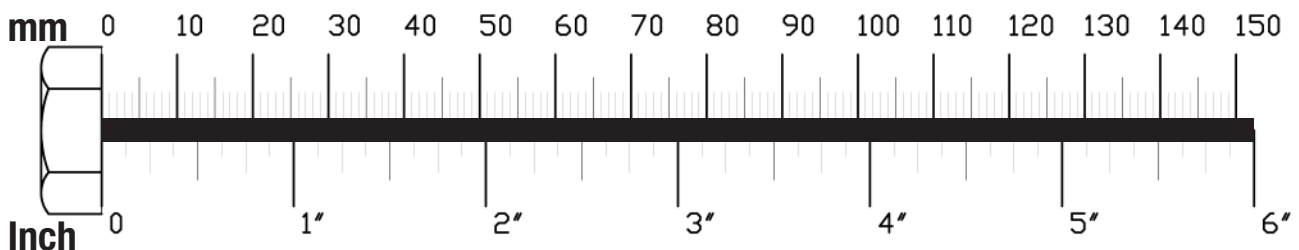
- A. Place two 2 1/2" Rubber Donuts (11) on Rear Base Frame (B) over the two widest openings. Slide two Chrome Guide Rods (R) through the two 2 1/2" Rubber Donuts (11) and into Rear Base Frame (B).
- B. Slide fifteen Weight Stack Plates (30) onto the two Chrome Guide Rods (R). Make sure the holes in the Weight Stack Plates (30) are facing forward as shown.
- C. Connect Top Plate (19) to Selector Rod (20) using:  
**One 49 (7/16" x 1" round bolt)**

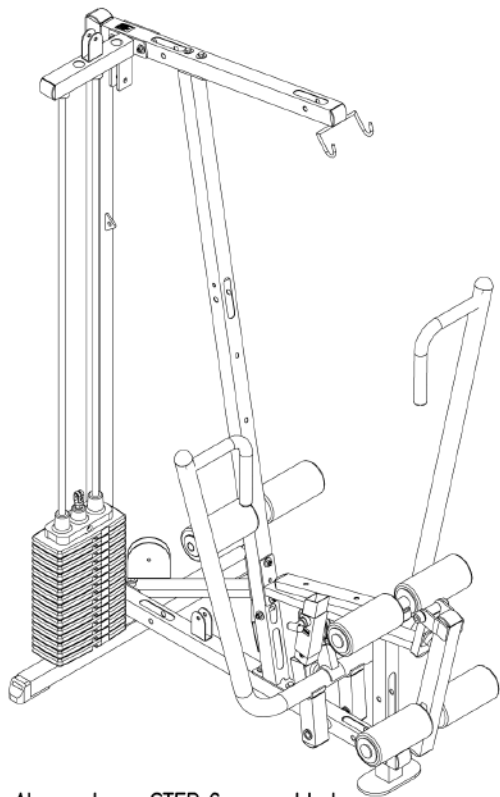
**Note:****Selector Rod Top Bolt (70) is preinstalled in Selector Rod (20).**

- D. Slide Top Plate (19) and Selector Rod (20) onto Guide Rods (R).

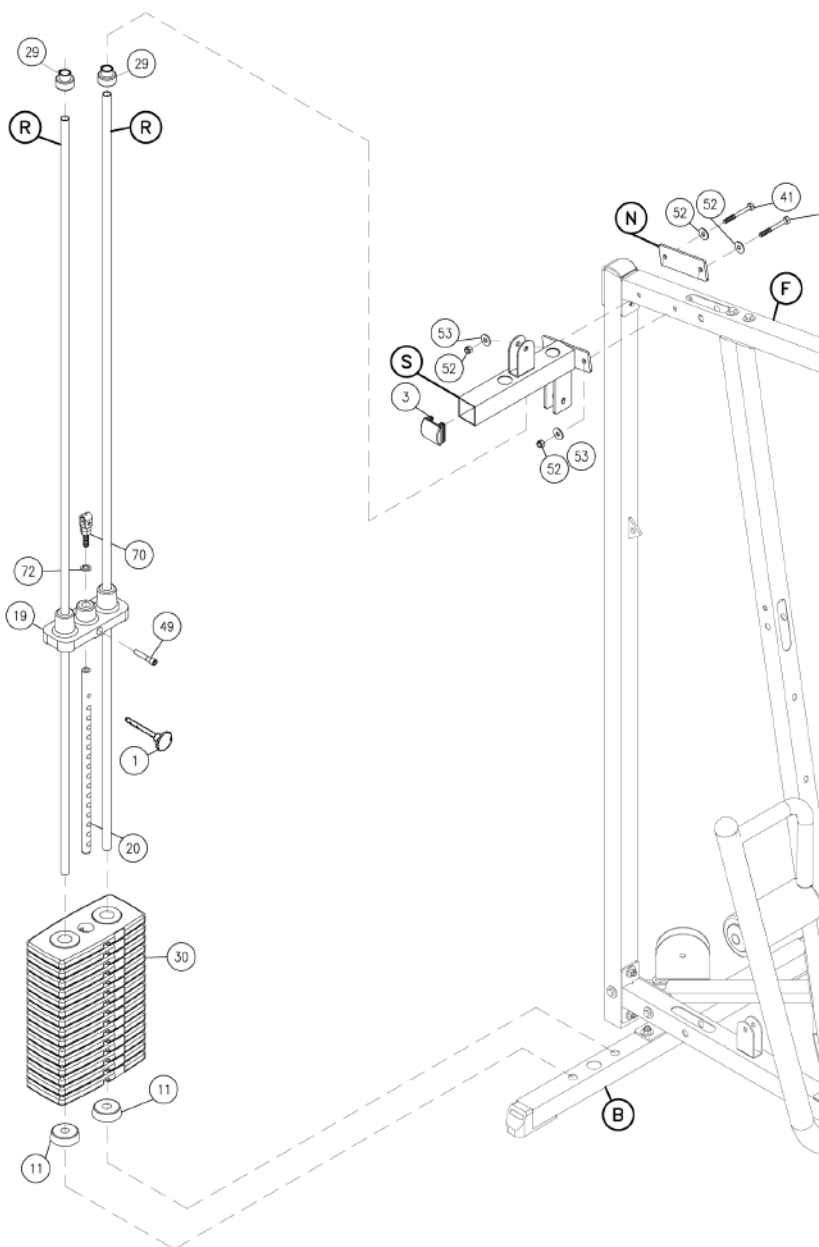
**Note:****Make sure that the Round Bolt (49) is facing forward as shown.**

- E. Slide two Shaft Collars (29) onto Guide Rods (R). Make sure the Allen Head Screws inside the Shaft Collars (29) are loose.
- F. Insert two Guide Rods (R) into Top Weight Stack Frame (S). Attach 2" x 5" Plate (N) and Top Weight Stack Frame (S) to Top Frame (F) using:  
**Two 41 (3/8" x 3" hex head bolt)**  
**Four 53 (3/8" washer)**  
**Two 52 (3/8" nylon lock nut)**  
Insert Convex End Cap (3) into Top Weight Stack Frame (S) as shown.
- G. Secure two Shaft Collars (29) into Top Weight Stack Frame (S). Tighten the Allen Head Screws in each Shaft Collar.
- H. You should now wrench tighten all bolts and nuts on the main frame unit.





Above shows STEP 6 assembled and completed.



**STEP****7**

**Be careful to assemble all components in the sequence they are presented.**

A. Attach Back Pad (T) to Angled Support Pillar (E) using:

**Two 47 (5/16" x 2 3/4" hex head bolt)**  
**Two 55 (5/16" spring lock washer)**  
**Two 54 (5/16" flat washer)**

**Note:**

**Do not over tighten Pad Bolts (47), over tightening will strip the T-nuts pressed into the wood.**

B. Attach Seat Pad (U) to Seat Frame (J) using:

**Two 48 (5/16" x 1 3/4" hex head bolt)**  
**Two 55 (5/16" spring lock washer)**  
**Two 54 (5/16" flat washer)**

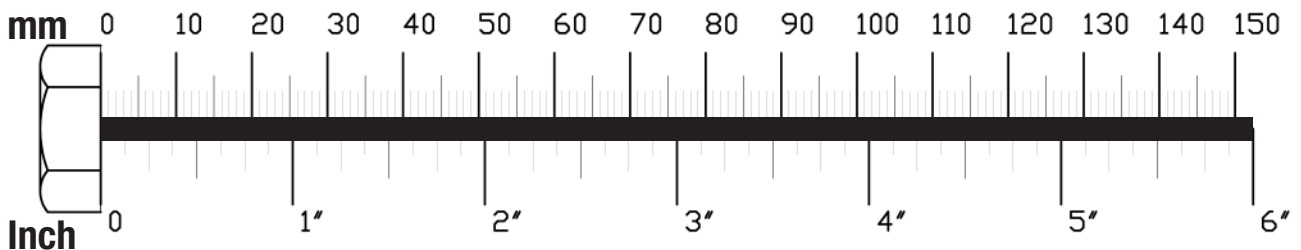
**Note:**

**Do not over tighten Pad Bolts (48), over tightening will strip the T-nuts pressed into the wood.**

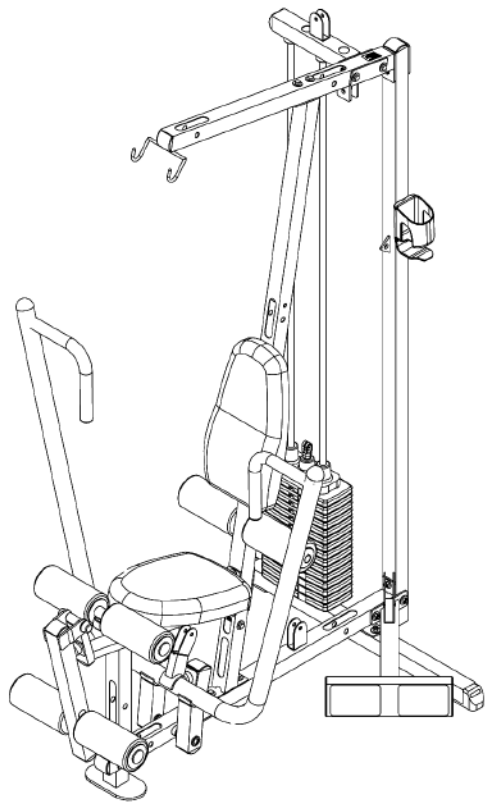
C. Connect the Water Bottle Bracket (31) to the Vertical Support Pillar (D) using:

**Two 32 (1/8" x 3/8" screw)**

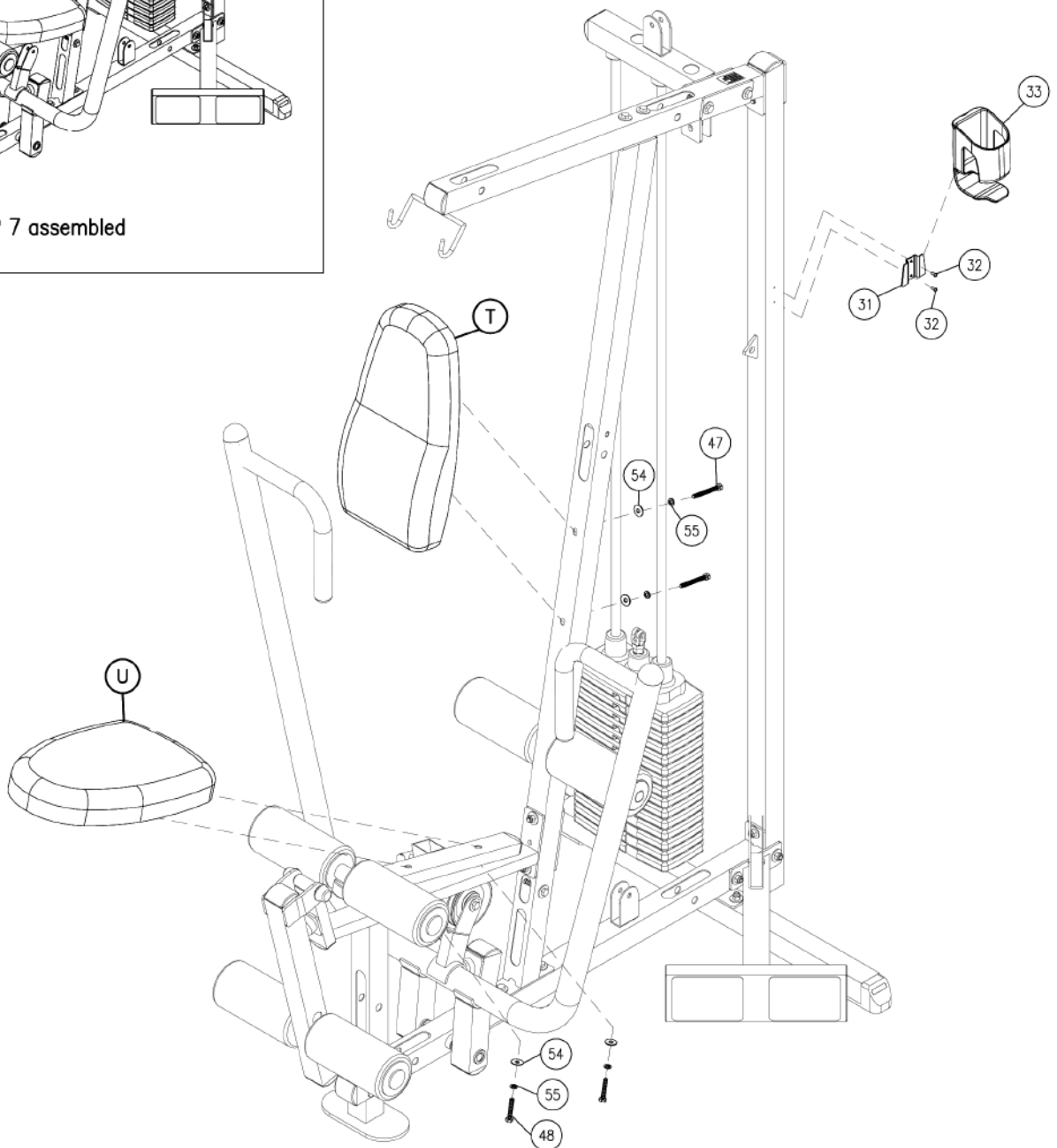
D. Slide the Water Bottle Holder (33) onto the Water Bottle Bracket (31) as shown.



**STEP**  
**7**



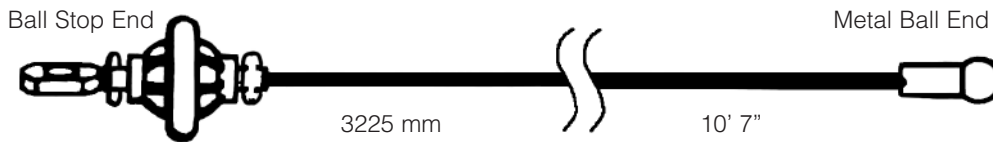
Above shows STEP 7 assembled and completed.



**STEP****8**

**Be careful to assemble all components in the sequence they are presented.**

**Lat Pulldown Cable (23)**



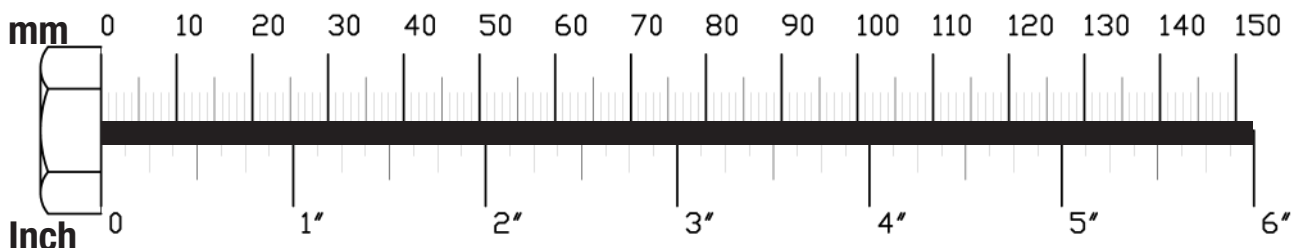
**Note:**

**All Pulleys in this step are 4 1/4" diameter, except where noted in step 8B. Leave all pulley bolts hand tight until step 12 is completed.**

- A. See diagram 1. Begin at the high pulley station. Route the metal ball end of Lat Cable (23) up and through the opening where the Pulley (A1) will be installed and then down through the next opening where Pulley (A2) will be installed.
- B. See diagram 2. Install 3 1/2" diameter Pulley (A1), under Cable (23) and into Top Frame (F) as shown. Install Pulley (A2) into Top Frame (F) under Cable (23) using:  
**Two 42 (3/8" x 2 3/4" hex head bolt)**  
**Four 13 (pulley spacer)**  
**Two 52 (3/8" nylon locknut)**
- C. Route Cable (23) through the top portion of the Adjustable Double Bracket (V) as shown in diagram 1. Hold Cable (23) in place by installing Pulley (A3) as shown in diagram 2 using:  
**One 45 (3/8" x 1 3/4" hex head bolt)**  
**One 52 (3/8" nylon locknut)**
- D. See diagram 1. Route Cable (23) up and through the opening above where Pulley (A4) will be installed and then down and through the opening next to Pulley (A5) as shown.
- E. Install Pulley (A5) to the top of the Top Weight Stack Frame (S), as shown using:  
**One 45 (3/8" x 1 1/2" hex head bolt)**  
**One 52 (3/8" nylon lock nut)**  
 Install Pulley (A4) to the bottom of the Top Weight Stack Frame (S), as shown using:  
**One 44 (3/8" x 1 3/4" hex head bolt)**  
**One 52 (3/8" nylon lock nut)**
- F. See diagram 1A. The Metal Ball End of Cable (23) should be hanging just above the Weight Stack. Remove Bolt (71) from Selector Rod Top Bolt (70), slide Metal Ball End of Cable (23) through Selector Rod Top Bolt (70). Attach Cable End Shaft (101) and securely tighten Allen Screw (102). Pull Cable (23) tight, so Cable End Shaft (101) fits securely inside Selector Rod Top Bolt (70). Reinstall Bolt (71) in Selector Rod Top Bolt (70).

**Note:**

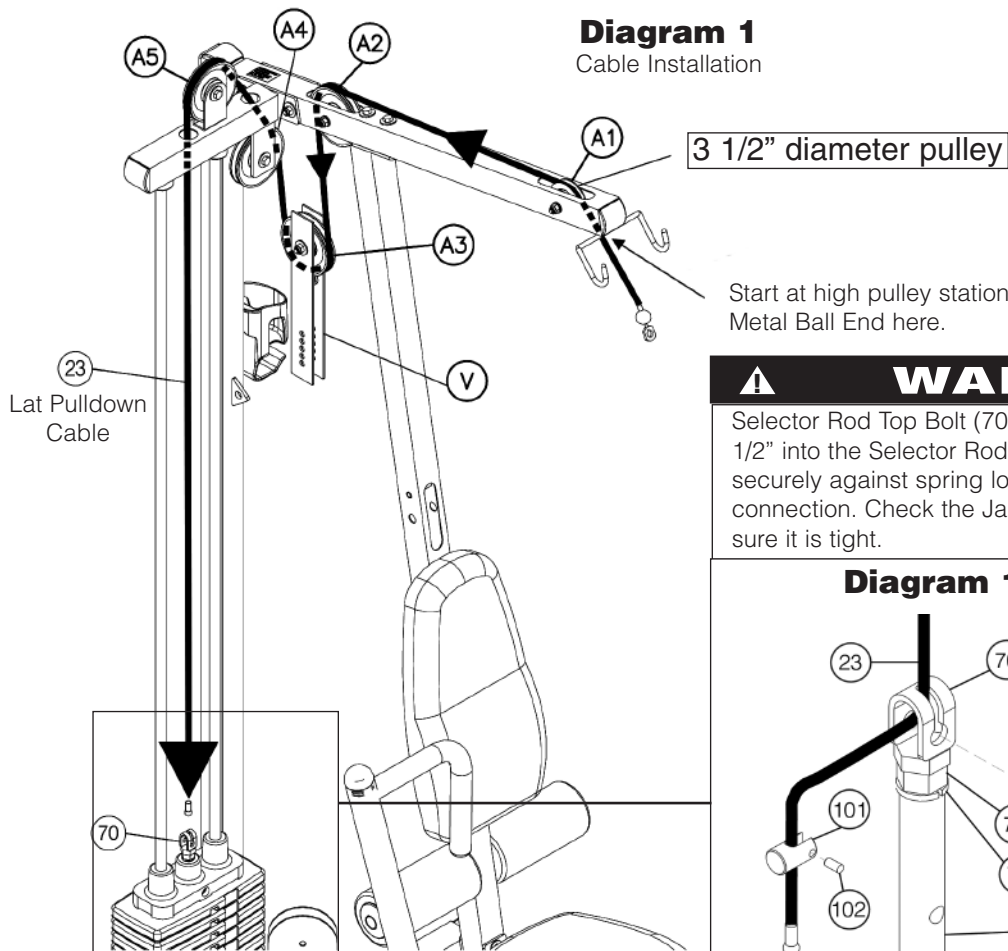
**Make sure the Selector Rod Top Bolt (70) is threaded inside Selector Rod (20) at least one half inch. Make sure Spring Lock Washer (72) is in place and wrench tighten Jam Nut (73).**





**Diagram 1**

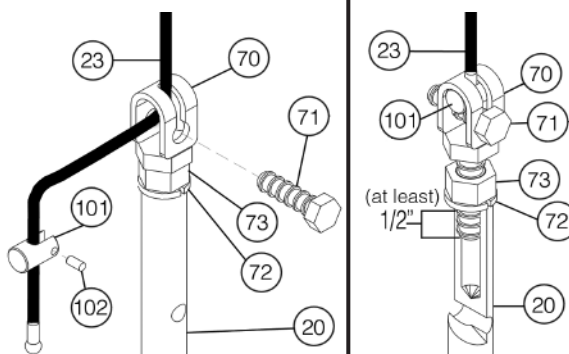
Cable Installation



**WARNING**

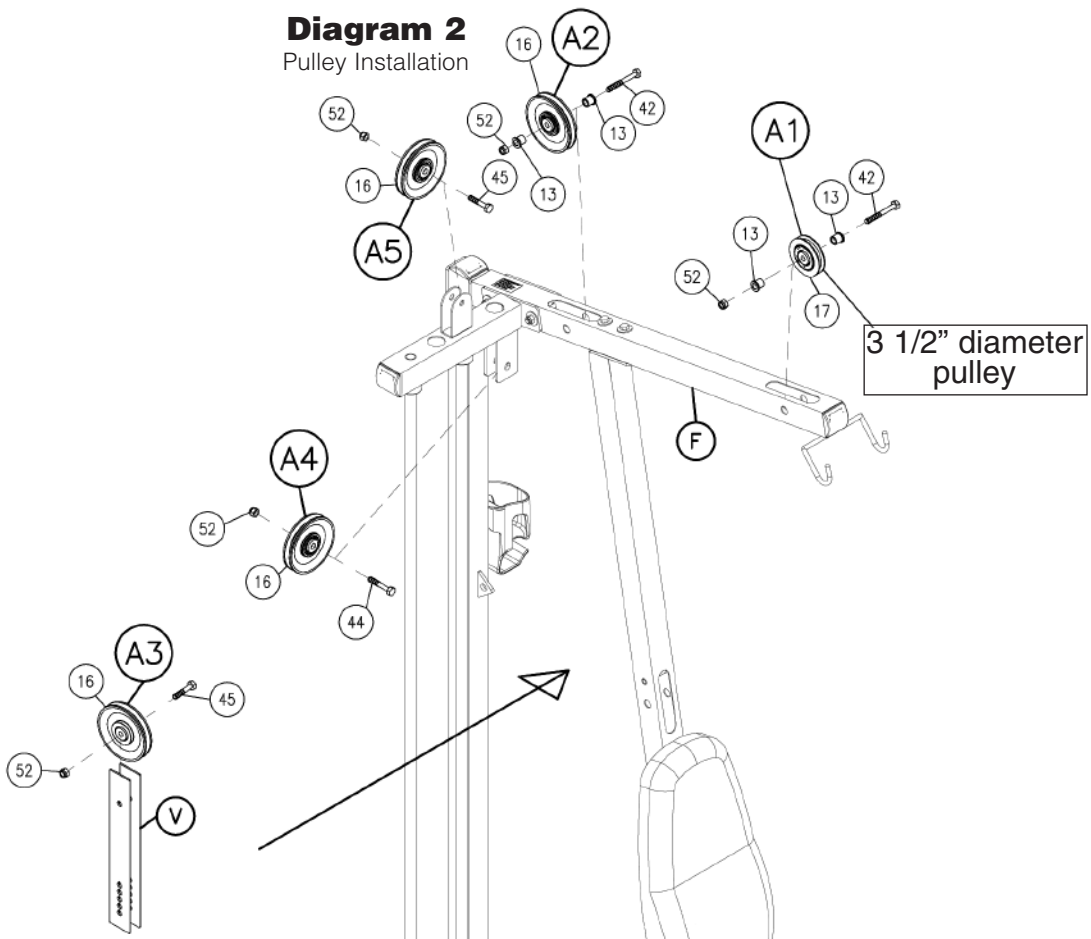
Selector Rod Top Bolt (70) must be threaded a minimum of 1/2" into the Selector Rod (20), and Jam Nut (73) tightened securely against spring lock washer (72) to ensure proper connection. Check the Jam Nut (73) once a week to make sure it is tight.

**Diagram 1A**



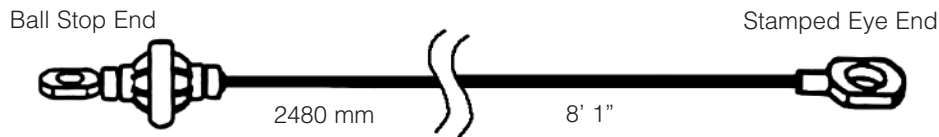
**Diagram 2**

Pulley Installation



**Be careful to assemble all components in the sequence they are presented.**

### **Ab Crunch Cable (25)**

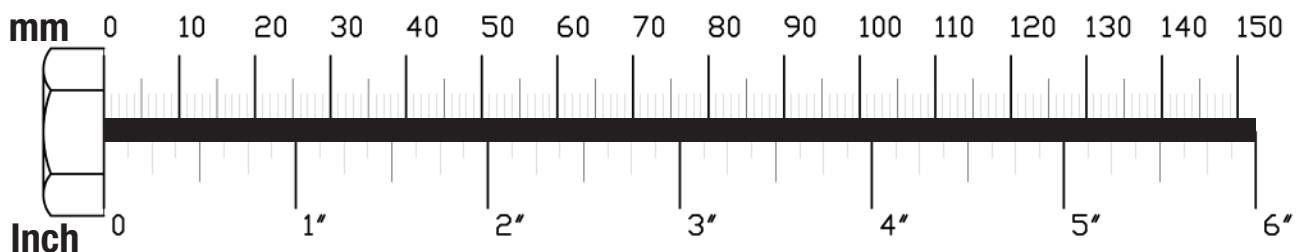


**Note:**

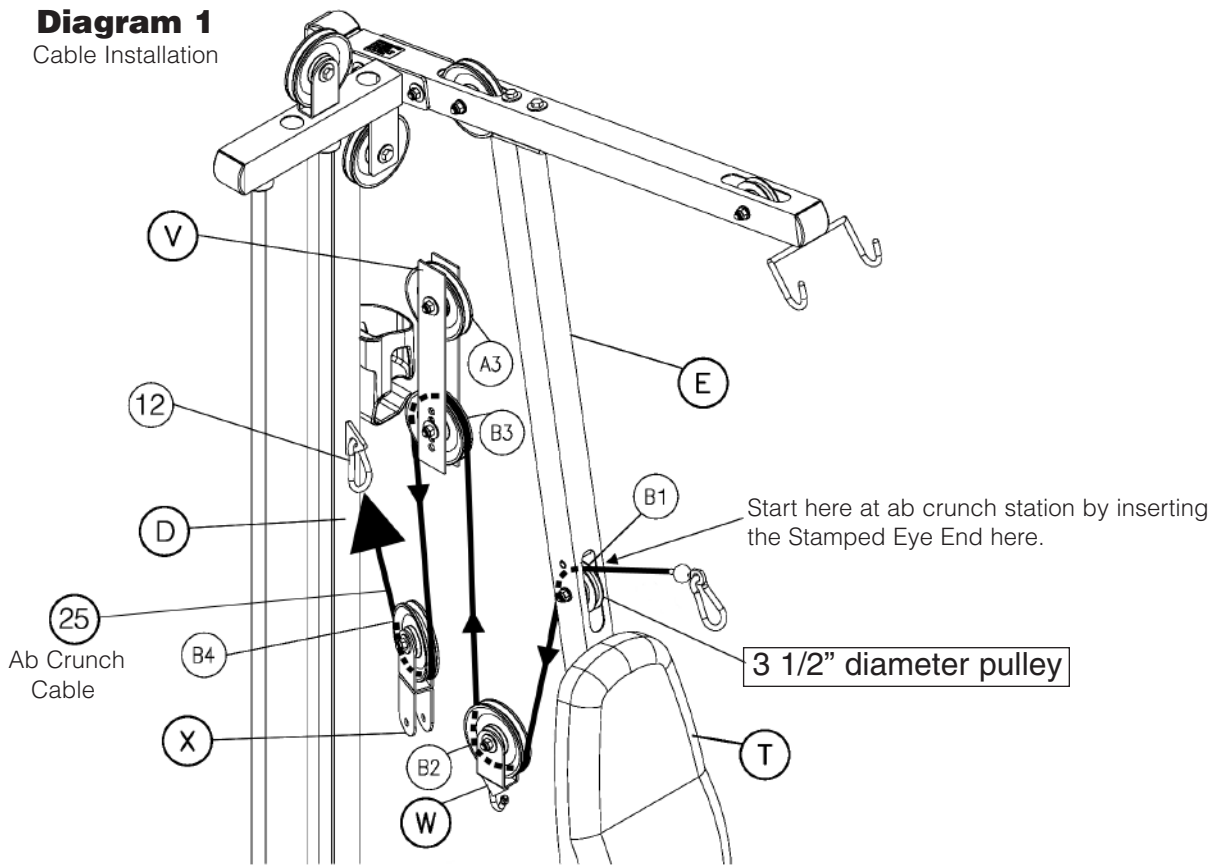
**All Pulleys in this step are 4 1/4" diameter, except where noted in step 9B.**

**Leave all pulley bolts hand tight until step 12 is completed.**

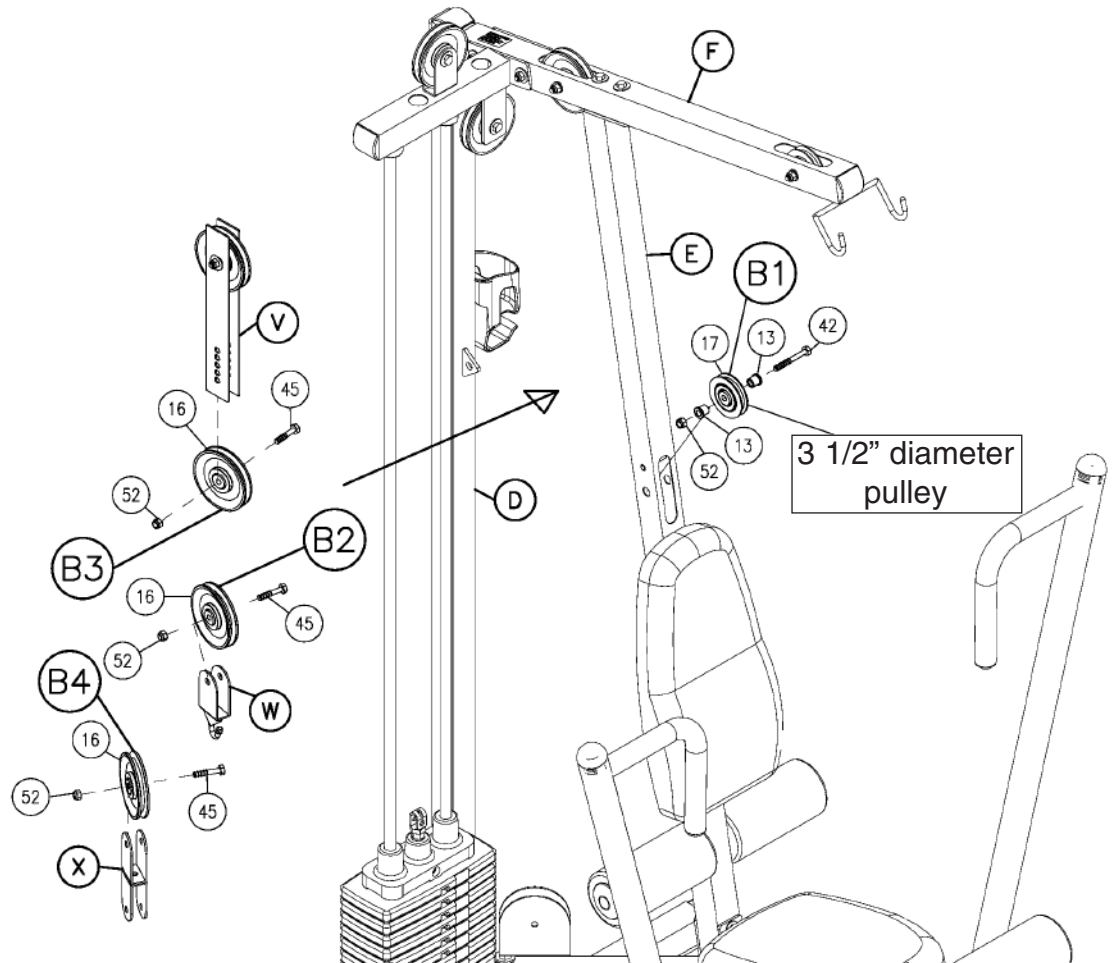
- A. See diagram 1. Insert stamped eye end of the Ab Crunch Cable (25) into the opening in Angled Support Pillar (E), above Back Pad (T), and pull entire length through.
- B. Install 3 1/2" diameter Pulley (B1), under Cable (25) and into Angled Support Pillar (E) as shown in diagram 2 using:  
**One 42 (3/8" x 2 3/4" hex head bolt)**  
**Two 13 (pulley spacer)**  
**One 52 (3/8" nylon lock nut)**
- C. Route Cable (25) through Single Pulley Hook (W) as shown in diagram 1 and hold cable in place by installing Pulley (B2) using:  
**One 45 (3/8" x 1 1/2" hex head bolt)**  
**One 52 (3/8" nylon lock nut)**
- D. See diagram 1. Route Cable (25) up through the bottom of Adjustable Double Bracket (V), and hold cable in place by installing Pulley (B3) as shown using:  
**One 45 (3/8" x 1 1/2" hex head bolt)**  
**One 52 (3/8" nylon lock nut)**
- E. Attach the stamped eye end of Cable (25) to the Vertical Support Pillar (D) with a Snap Link (12) as shown in diagram 1.
- F. See diagram 1. Take up the slack in the cable by hanging the Double Bracket (X) in the proper position and install Pulley (B4) as shown in diagram 2 using:  
**One 45 (3/8" x 1 1/2" hex head bolt)**  
**One 52 (3/8" nylon lock nut)**



**Diagram 1**  
Cable Installation

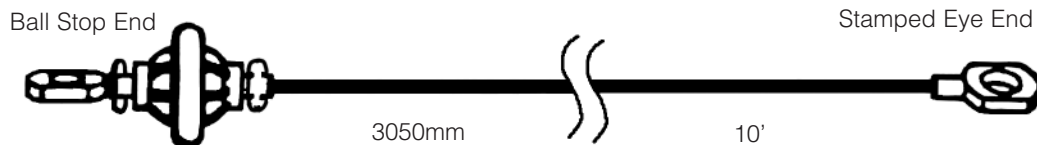


**Diagram 2**  
Pulley Installation



**Be careful to assemble all components in the sequence they are presented.**

### **Low Pulley / Leg Extension Cable (24)**

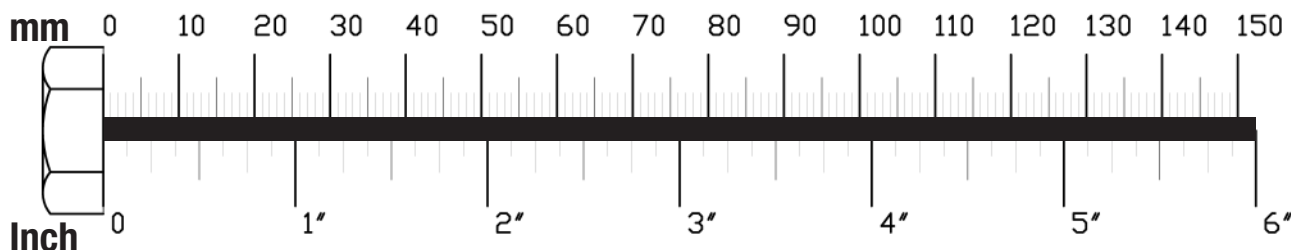


**Note:**

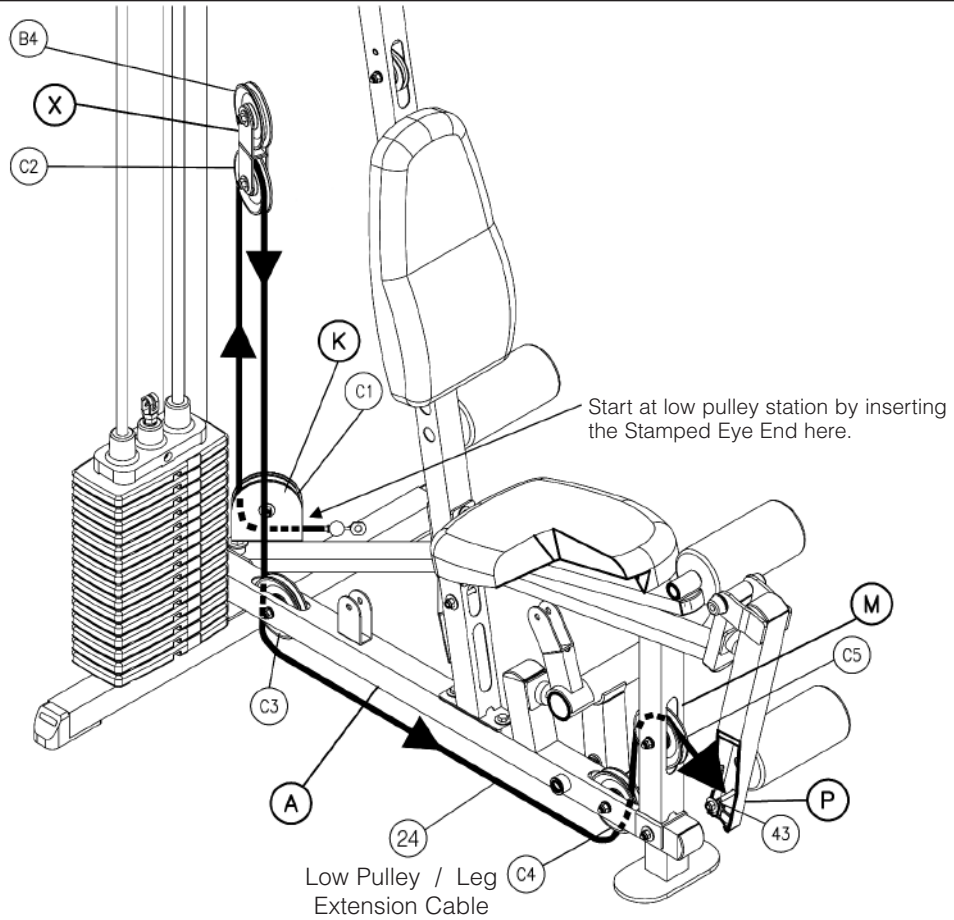
**All Pulleys in this step are 4 1/4" diameter.**

**Leave all pulley bolts hand tight until step 12 is completed.**

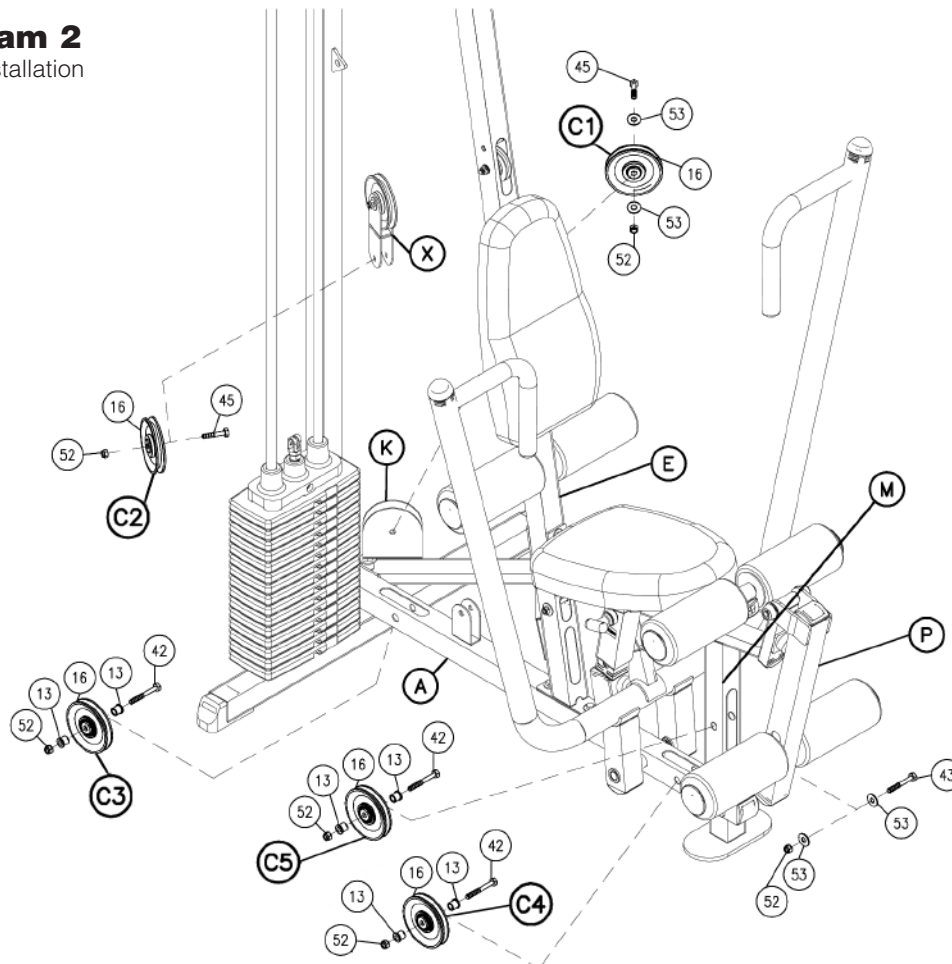
- A. See diagram 1. Insert stamped eye end of the Low Pulley / Leg Extension Cable (24) through Low Pulley Bracket (K) and install Pulley (C1) as shown using:
  - One 45 (3/8" x 1 1/2" hex head bolt)**
  - Two 53 (3/8" flat washer)**
  - One 52 (3/8" nylon lock nut)**
- B. Route Cable (24) up and through the bottom portion of the Double Pulley Bracket (X), and hold Cable (24) in place by installing Pulley (C2) as shown using:
  - One 45 (3/8" x 1 1/2" hex head bolt)**
  - One 52 (3/8" nylon lock nut)**
- C. See diagram 1. Route Cable (24) down and through the hole in the Main Base Frame (A), where Pulley (C3) will be installed. Route Cable (24) under Main Base Frame (A).
- D. Route Cable (24) up and through the opening in the Main Base Frame (A) where Pulley (C4) will be installed. Route Cable (24) through the opening in the Seat / Extension Frame (M). Attach Stamped eye end of Cable (24) to the Leg Frame (P) as shown in diagram 2 using:
  - One 42 (3/8" x 2 3/4" hex head bolt)**
  - Two 13 (pulley spacer)**
  - One 52 (3/8" nylon lock nut)**
- E. Insert Pulley (C5) into Seat / Extension Frame (M), under Cable (24), as shown using:
  - One 42 (3/8" x 2 3/4" hex head bolt)**
  - Two 13 (pulley spacer)**
  - One 52 (3/8" nylon lock nut)**
- F. Take up the slack in the Cable (24) by installing Pulleys (C3) and (C4) into Main Base Frame (A) as shown in diagram 2 using for each pulley:
  - One 42 (3/8" x 2 3/4" hex head bolt)**
  - Two 13 (pulley spacer)**
  - One 52 (3/8" nylon lock nut)**



**Diagram 1**  
Cable Installation

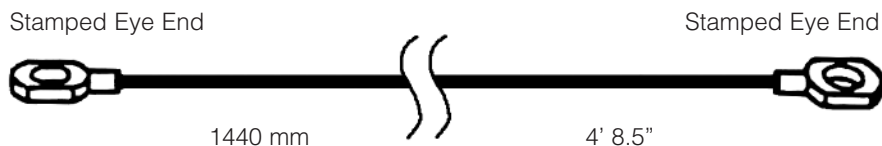


**Diagram 2**  
Pulley Installation



**Be careful to assemble all components in the sequence they are presented.**

### **Seated Press Cable (22)**

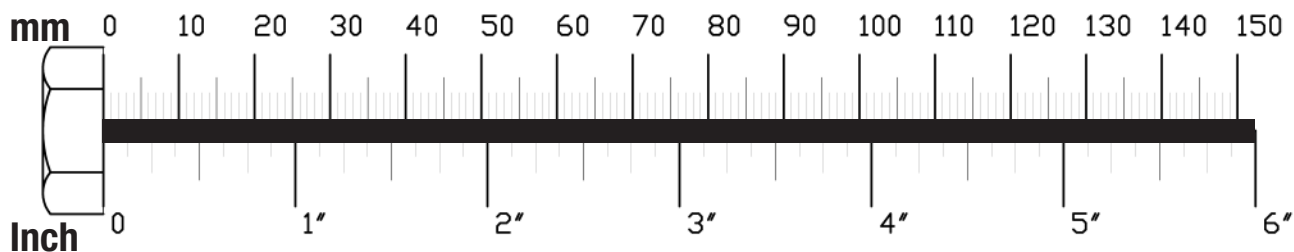


**Note:**

**All Pulleys in this step are 4 1/4" diameter.**

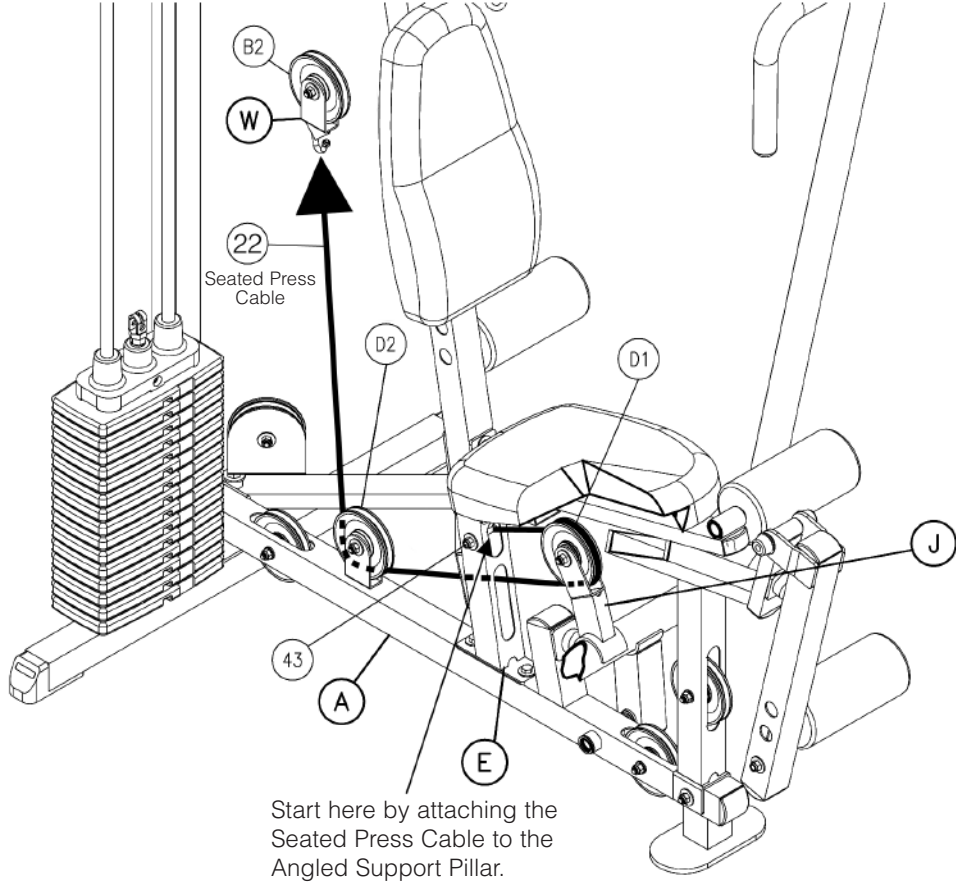
**Leave all pulley bolts hand tight until step 12 is completed.**

- A. See diagram 1. Attach either end of Seated Press Cable (22) to Angled Support Pillar (E) as shown using:  
**One 43 (3/8" x 2 1/2" hex head bolt)**  
**Two 53 (3/8" flat washer)**  
**One 52 (3/8" nylon lock nut)**
- B. Route Cable (22) through the pulley bracket on Bench Press Frame (J) and install Pulley (D1) as shown using:  
**One 45 (3/8" x 1 1/2" hex head bolt)**  
**One 52 (3/8" nylon lock nut)**
- C. Route Cable (22) through Angled Support Pillar (E) as shown in diagram 1.
- D. Route Cable (22) through pulley bracket where Pulley (D2) will be installed and hold cable in place by installing Pulley (D2) as shown in diagram 2 using:  
**One 45 (3/8" x 1 1/2" hex head bolt)**  
**One 52 (3/8" nylon lock nut)**
- E. Connect the end of Cable (22) to the hook on the bottom of Single Pulley Hook (W) as shown in diagram 1.

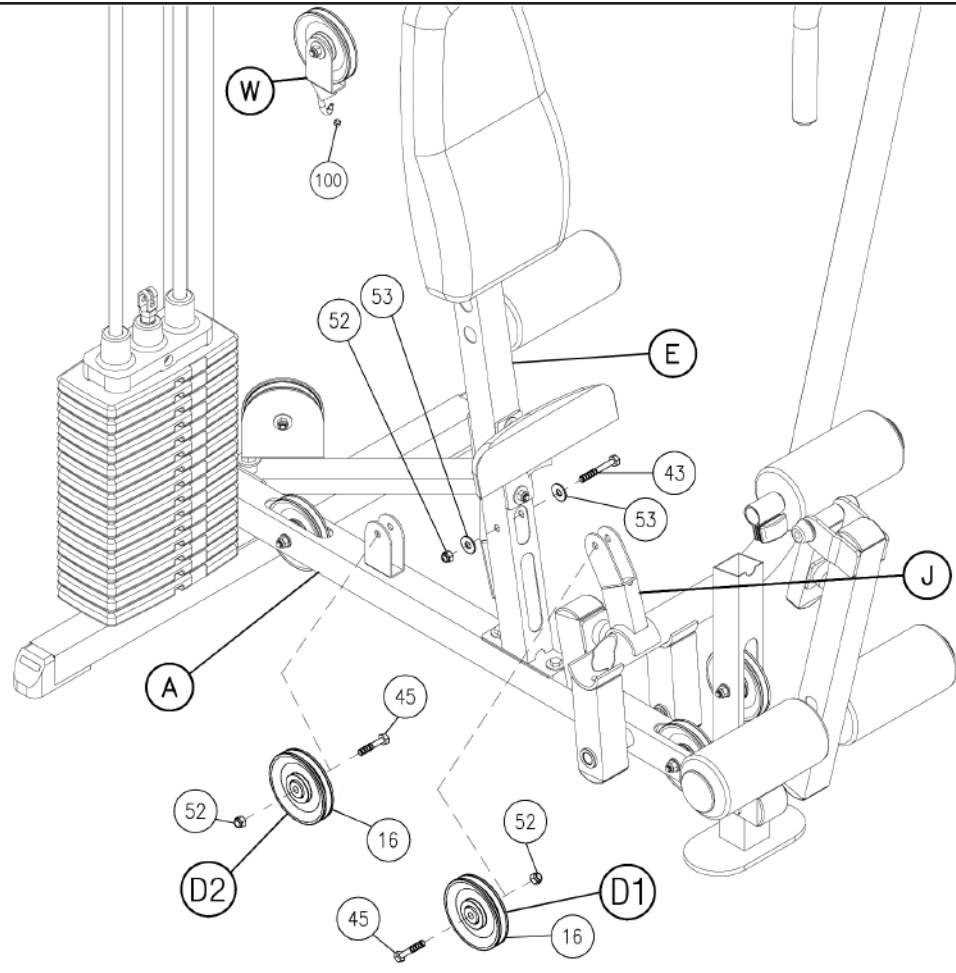


**Diagram 1**  
Cable Installation

**STEP**  
**11**



**Diagram 2**  
Pulley Installation



**Be careful to assemble all components in the sequence they are presented.**

**NOW IS THE TIME TO MAKE ALL NECESSARY CABLE ADJUSTMENTS**

After cable installation is complete you must check all cables for proper tension. Obvious signs that cable tension problems exist include:

- Top Plate (19) does not rest directly on the top Weight Stack Plate (30).
- The holes in the Selector Rod (20) do not line up with holes in the Weight Stack Plates (30).
- Cable(s) are sloppy and there is no resistance from the weight stack for the first few inches of the exercise.

There are Three areas for cable adjustment on the G1S:

- (A) Selector Rod Top Bolt (70)
- (B) Adjustments in Adjustable Double Bracket (V).
- (C) Rubber Stop (35) on Main Base Frame (A).

**SEE NOTE 1 ON PAGE 25**

If there is too much tension, and the Top Plate (19) is not resting directly on top of the weight stack plates:

- 1st. -Tighten Rubber Stop (35).
- 2nd. -Move Pulley (B3) down to a lower hole in Adjustable Double Bracket (V), or move Pulley (A3) up to a higher hole in Adjustable Double Bracket (V).

If there is too much play or excessive slack;

- 1st. -Loosen Rubber Stop (35).
- 2nd. -Move Pulley (B3) up to a higher hole in Adjustable Double Bracket (V), or move Pulley (A3) down to a lower hole in Adjustable Double Bracket (V).
- 3rd. -Screw the Selector Rod Top Bolt (70) farther into the Selector Rod (20) of the weight stack.

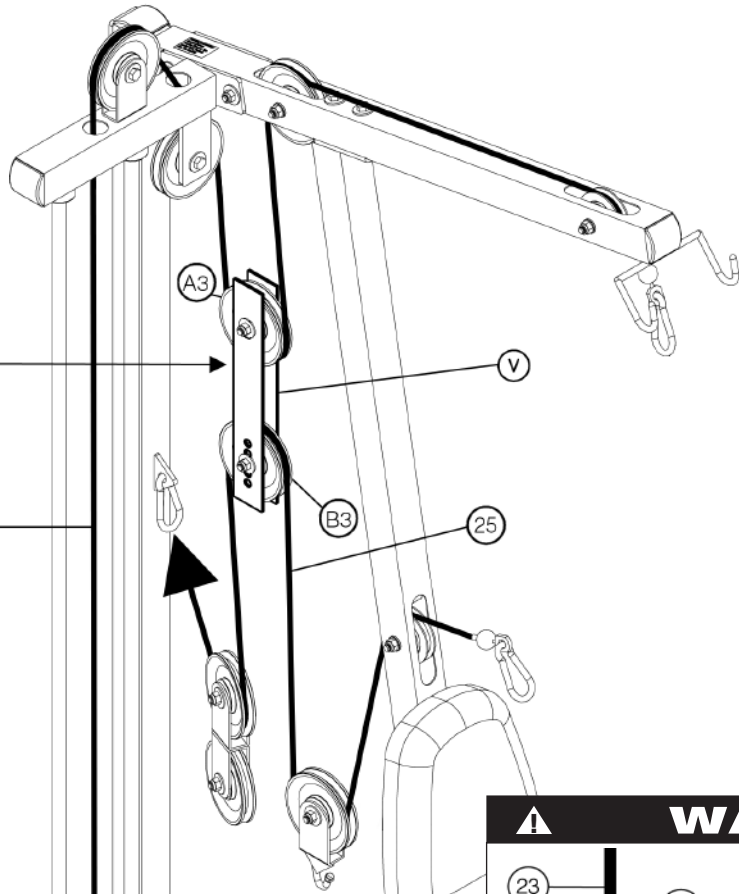
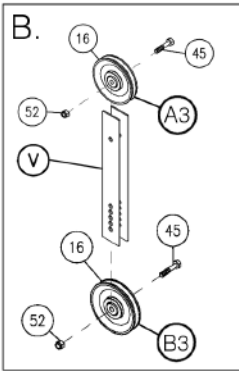
**NOTE:**

**Cables should be inspected daily and adjusted periodically to ensure safe and smooth operation.**

**NOTE:**

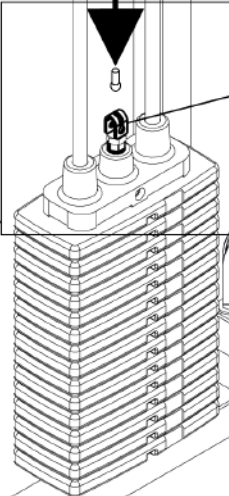
**After cable adjustment is complete, you should now wrench tighten all bolts. Do NOT re-tighten any pad bolts.**





23

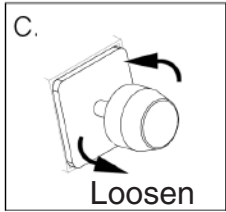
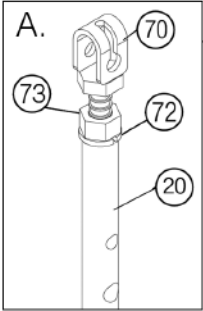
**NOTE 1**  
Check Jam Nut (73) weekly to be sure it is tight and locked onto the Selector Rod (20).



70  
Selector Rod Top Bolt

**WARNING**

Selector Rod Top Bolt (70) must be threaded a minimum of 1/2" into the Selector Rod (20), and Jam Nut (73) tightened securely against spring lock washer (72) to ensure proper connection.



Turn and loosen Rubber Stop (35) to take up space and tighten cable.

# G 1 S Mainframe Parts List

<b>KEY#</b>	<b>QTY</b>	<b>PART#</b>	<b>DESCRIPTION</b>
A	1	G1SMBF-A	MAIN BASE FRAME
B	1	G1SRBF-B	REAR BASE FRAME
D	1	G1SVSP-D	VERTICAL SUPPORT PILLAR
E	1	G1SASP-E	ANGLED SUPPORT PILLAR
F	1	G1STF-F	TOP FRAME
G	1	G1SP-G	2"X4" PLATE
H	3	G1SFRB-H	FOAM ROLLER BAR
J	1	G1SBPF-J	BENCH PRESS FRAME
K	1	G1SLPB-K	LOW PULLEY BRACKET
L	1	G1SFB-L	FOOT BRACE
M	1	G1SSEF-M	SEAT/EXTENSION FRAME
N	2	G1SP-N	2" X 5 1/2" PLATE
P	1	G1SLF-P	LEG FRAME
Q	1	G1SSF-Q	SEAT FRAME
R	2	G1SCGR-R	CHROME GUIDE ROD
S	1	G1STWSF-S	TOP WEIGHT STACK FRAME
V	1	G1SWADB-V	ADJUSTABLE DOUBLE BRACKET
W	1	G1SSPH-W	SINGLE PULLEY HOOK
X	1	G1SWDB-X	DOUBLE BRACKET

**Part numbers are required when ordering parts.**

# G 1 S Hardware List

KEY#	QTY	PART#	DESCRIPTION
1	1	JPIN4.25	WEIGHT STACK PIN 4 1/4" X 7/16"
2	1	JSCH.18	STEEL CHAIN 3/16"
3	7	JCEC22	CONVEX END CAP 2" X 2" I.D. 1 3/8"
4	2	JCEC22LE	CONVEX END CAP 2" X 2" I.D. 1 7/16"
5	2	JCEC24	CONVEX END CAP 2" X 4"
6	3	JCEC12	CONVEX END CAP 1" X 2"
7	1	JCEC1.75X1.75	END CAP 1 3/4" X 1 3/4"
8	6	JREC1	ROLLER END CAP 1"
9	2	JFC22	FOOT CAP 2" X 2"
10	1	JFP22.5	FLAT PLATE 2" X 5 1/2"
11	2	JRD2.5	RUBBER DONUT 2 1/2"
12	5	JSNAP3	SNAP LINK
13	12	JPS.62X.37	PULLEY SPACER 5/8" OD X 3/8" ID X 5/8" L
15	2	JGT5.5	GRIP TAPE 5 1/2" X 3 3/4"
16	14	JPP4.25W.75	PLASIC PULLEY 4 1/4" X 3/4" WIDE
17	2	JPP3.5W.75	PLASIC PULLEY 3 1/2" X 3/4" WIDE
18	6	JFOAM3.5x8	FOAM ROLLER 3 1/2" X 8"
19	1	JTP10	TOP PLATE (10 lbs.)
20	1	JSR15	SELECTOR ROD (15 selector holes)
21	2	JBC.5	BOLT COVER 1/2"
26	4	JPW3	PLASIC WASHER 3"
27	1	JRP1.5X1.75	RUBBER PAD 1 1/2" X 1 3/4"
28	6	JREC1.5	ROUND END CAP 1 1/2"
29	2	JSC1.37X.75	SHAFT COLLAR 1 3/8" OD X 3/4" ID 1.5" L
30	15	JSP10	WEIGHT PLATE
31	1	JWBB	WATER BOTTLE BRACKET
32	2	JS.125X.37FT	SCREW 1/8" X 3/8" FULL THREAD
33	1	JWBH	WATER BOTTLE HOLDER
34	2	JJN.37	JAM NUT 3/8"
35	1	JRS1.5	RUBBER STOP (1 1/2" diameter)

**Continued on next page**



**Part numbers are required when ordering parts.**

## G 1 S H a r d w a r e ( c o n t i n u e d )

KEY#	QTY	PART#	DESCRIPTION
40	1	JHEX.5X3.25PTB	HEX HEAD BOLT 1/2" X 3 1/4" PARTIAL THREAD
41	4	JHEX.37X3PTB	HEX HEAD BOLT 3/8" X 3" PARTIAL THREAD
42	13	JHEX.37X2.75PTB	HEX HEAD BOLT 3/8" X 2 3/4" PARTIAL THREAD
43	6	JHEX.37X2.5PTB	HEX HEAD BOLT 3/8" X 2 1/2" PARTIAL THREAD
44	1	JHEX.37X1.75PTB	HEX HEAD BOLT 3/8" X 1 3/4" PARTIAL THREAD
45	9	JHEX.37X1.5PTB	HEX HEAD BOLT 3/8" X 1 1/2" PARTIAL THREAD
46	2	JCB.37X2.75PTB	CARRIAGE BOLT 3/8" X 2 3/4" PARTIAL THREAD
47	2	JHEX.31X2.75PTB	HEX HEAD BOLT 5/16" X 2 3/4" PARTIAL THREAD
48	2	JHEX.31X1.75PTB	HEX HEAD BOLT 5/16" X 1 3/4" PARTIAL THREAD
49	1	JRAH.43X1.5PTB	ROUND ALLEN HEAD 7/16" X 1 1/2" PARTIAL THREAD
50	2	JNLN.5	NYLON LOCK NUT 1/2"
52	32	JNLN.37	NYLON LOCK NUT 3/8"
53	32	JWFLT.37	WASHER 3/8"
54	4	JWFLT.31	WASHER 5/16"
55	4	JWSW.31	SPRING LOCK WASHER 5/16"
56	2	JREC.5	ROUND END CAP WASHER 1/2"
60	1	JTSPP3	T-SHAPED POP PIN 3" L
62	2	JREC2	ROUND END CAP 2"
63	2	JAS.31X.31	ALLEN SCREW 5/16" X 5/16" FULL THREAD
64	2	JBB.87X.75	OILITE BUSHING 7/8"OD 3/4"ID - PREINSTALLED
65	2	JBB.75X.5	OILITE BUSHING 3/4"OD 1/2"ID 7/16"L- PREINSTALLED
66	2	JBB.75X.5	OILITE BUSHING 3/4"OD 1/2"ID 7/16"L- PREINSTALLED
70	1	JSRTB.5	SELECTOR ROD TOP BOLT 1/2" X 2" FULL THREAD
71	1	JHEX.37X.87FTB	HEX HEAD BOLT 3/8" X 7/8" FULL THREAD
72	1	JSLW.5	SPRING LOCK WASHER 1/2"
73	1	JJN.5	JAM NUT 1/2"
100	1	JACN.19	ACORN CAP NUT 3/16" ID - PREINSTALLED
101	1	JCES	CABLE END SHAFT 3/4" L
102	1	JAS.125X.25	ALLEN SCREW 1/8" X 1/4" FULL THREAD
103	1	JWSPL	WEIGHT STACK PIN LANYARD

**Part numbers are required when ordering parts.**

## P a d s L i s t

KEY#	QTY	PART#	DESCRIPTION
T	1	G1SBP-T	BACK PAD
U	1	G1SSP-U	SEAT PAD

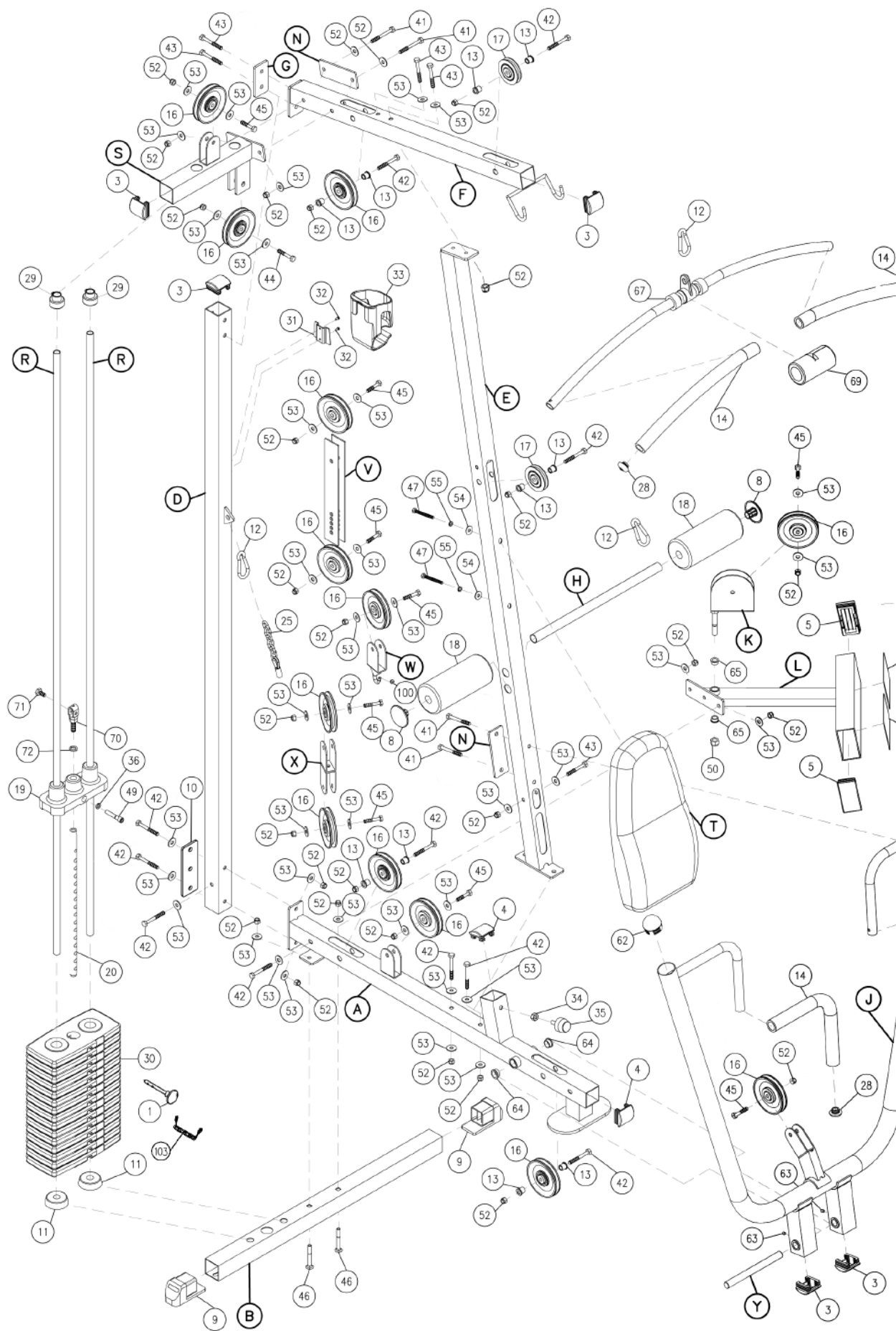
## C a b l e L i s t

KEY#	QTY	PART#	DESCRIPTION
22	1	JSPC1440	SEATED PRESS CABLE
23	1	JLP3240	LAT PULLDOWN CABLE
24	1	JLP3050	LOW PULLEY / LEG EXTENSION CABLE
25	1	JACC2210	AB CRUNCH CABLE

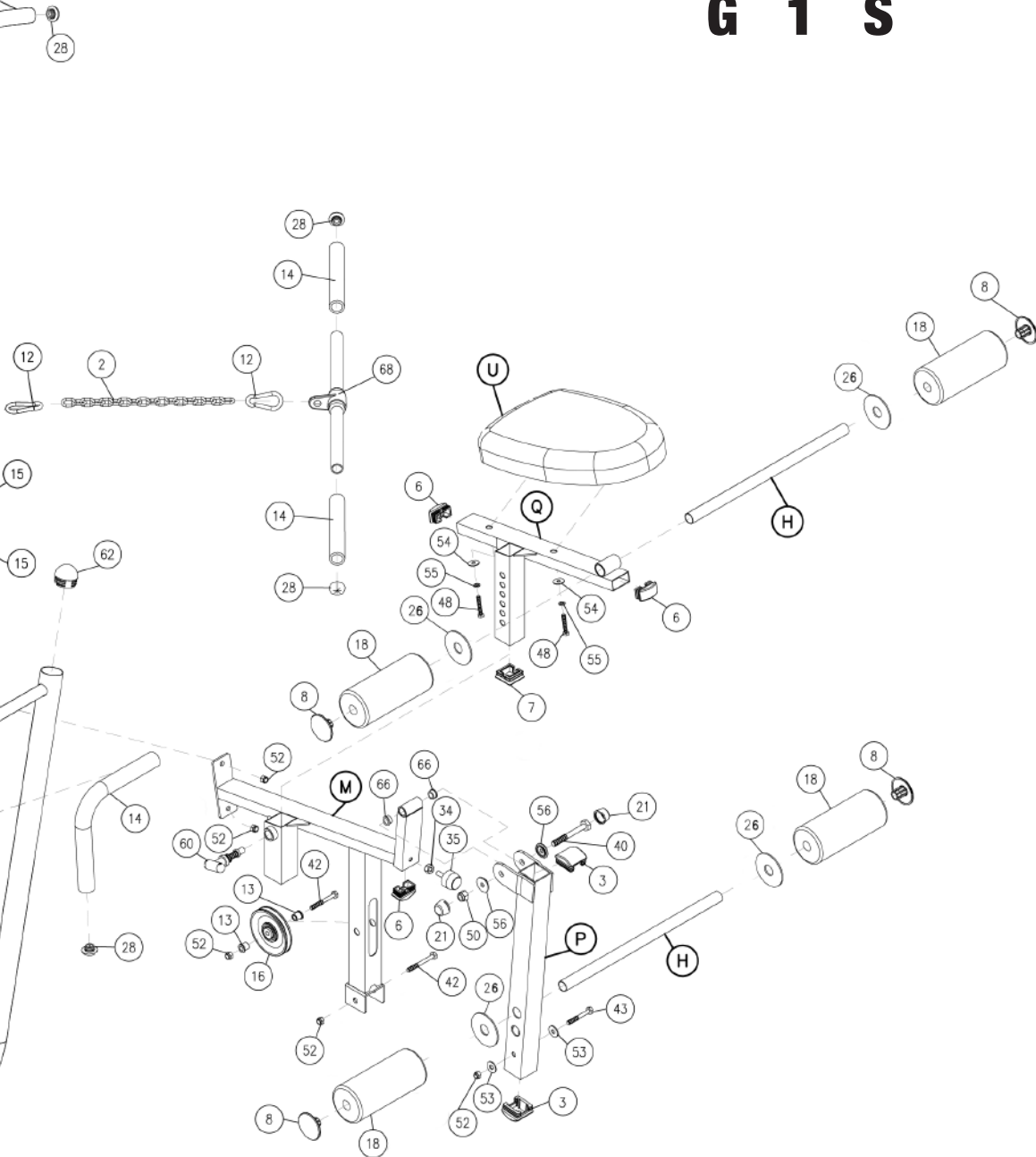
## A c c e s s o r i e s L i s t

KEY#	QTY	PART#	DESCRIPTION
67	1	JE15LB	LAT BAR
68	1	JE15LRB	LOW ROW BAR
69	1	JE15LBP	LAT BAR PAD
80	2	JFG18	FOAM GRIP 1 1/2" OD X 18" L -PREINSTALLED
81	2	JFG8.5	FOAM GRIP 1 1/2" OD X 8 1/2" L -PREINSTALLED
82	2	JFG14	FOAM GRIP 1 1/2" OD X 14" L -PREINSTALLED

**Part numbers are required when ordering parts.**



# EXPLODED VIEW DIAGRAM G 1 S



© Copyright 2003. Body-Solid. All rights reserved. Body-Solid reserves the right to change design and specifications when we feel it will improve the product. Body-Solid machines maintain several patented and patent pending features and designs. All rights reserved on all design patents and utility patents.