

Owners Manual

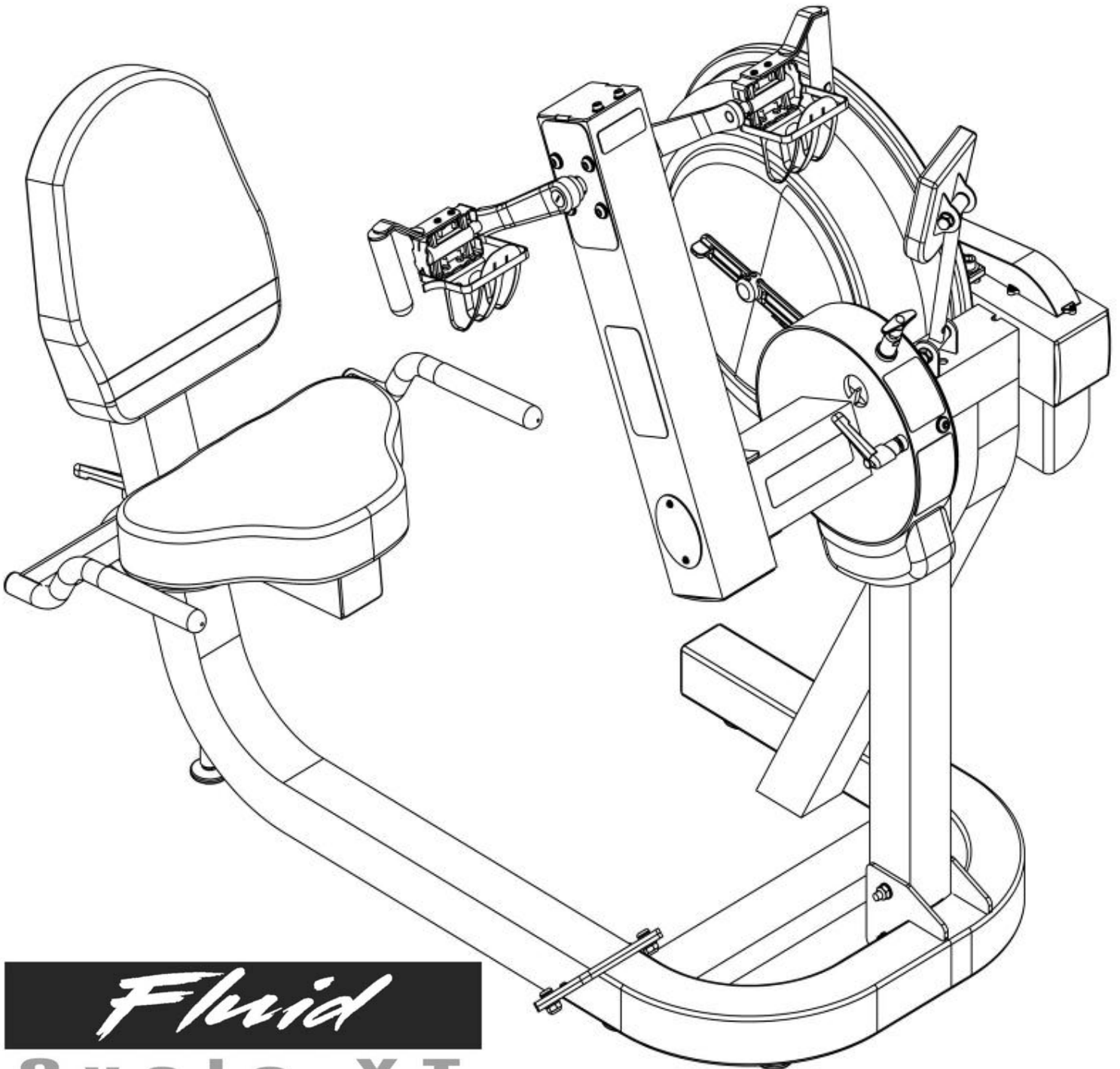

Fluid

Cycle XT

E720



FIRST DEGREE FITNESS
FLUID INNOVATION

www.firstdegreefitness.com

Training with E720

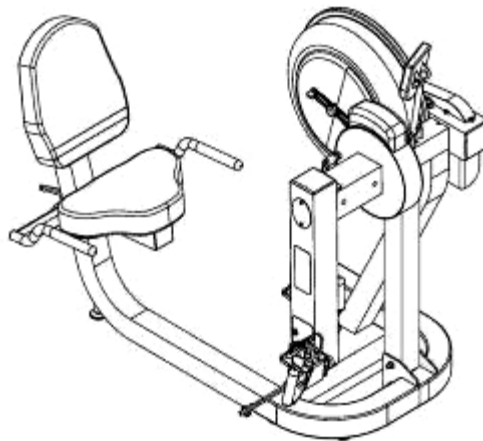
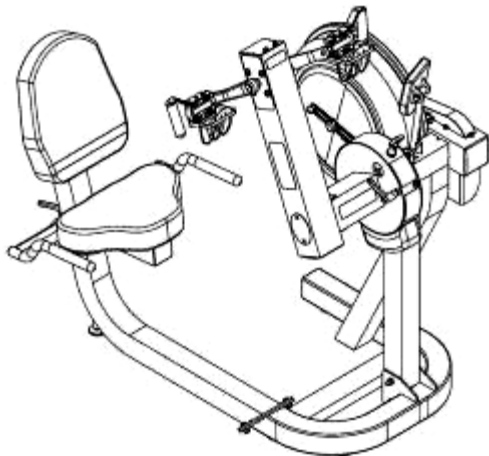

As with any piece of fitness equipment, consult a physician before beginning your E720 exercise program.

Contents

1. Contents of E720 Box.
2. E720 assembly instructions.
3. Tank filling and water treatment.
4. Long term water treatment and basic operation.
5. E720 Control arm.
6. Maintenance.
7. Troubleshooting guide
8. The E720 Ergometer with USB Function
9. Tank belt drive adjustment.
10. Parts list and Warranty.



CAUTION

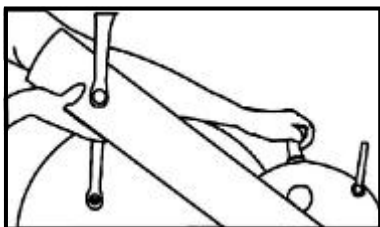

Use two hands and follow all safety instructions whenever raising or lowering the E720 control arm.



Warning

Do not remove feet or hands while crank is in motion. The crank will continue to rotate and could cause injury.

Box Contents

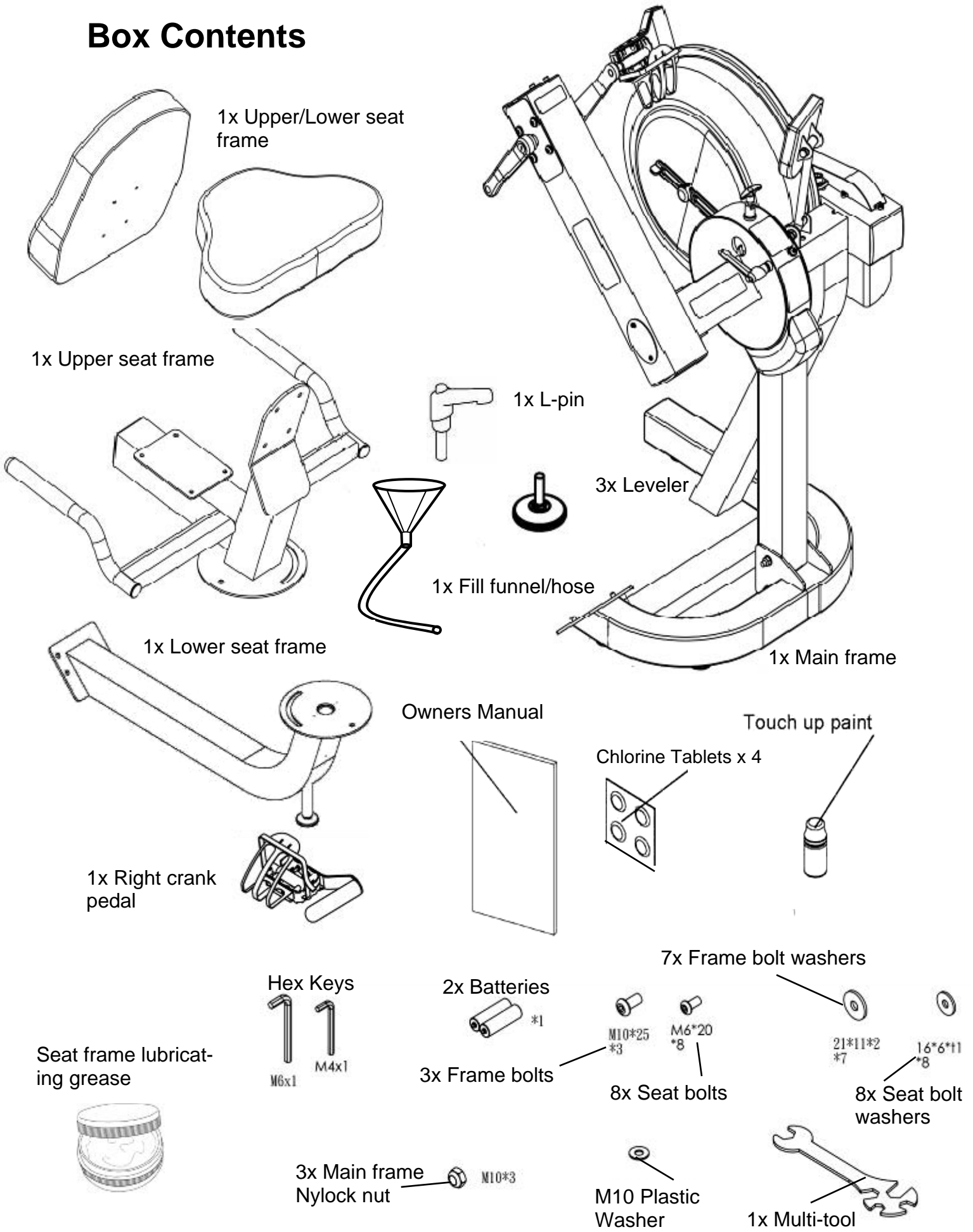

1x Upper/Lower seat frame

1x Upper seat frame

1x L-pin

3x Leveler

1x Fill funnel/hose

1x Lower seat frame

1x Main frame

Owners Manual

Touch up paint

Chlorine Tablets x 4

1x Right crank pedal

7x Frame bolt washers

Hex Keys

2x Batteries

Seat frame lubricating grease

M6x1
M4x1

3x Frame bolts

M10*25*3
M6*20*8

21*11*2*7
16*6*11*8

8x Seat bolts

8x Seat bolt washers

3x Main frame Nylock nut M10*3

M10 Plastic Washer

1x Multi-tool

E720 Assembly Instructions

Step 1: Attach upper seat to upper seat frame using 4x M6x20mm bolts and 4x 16x6xl washers.

Step 2: Attach lower seat to upper seat frame using 4x M6x20mm bolts and 4x 16x6xl washers.

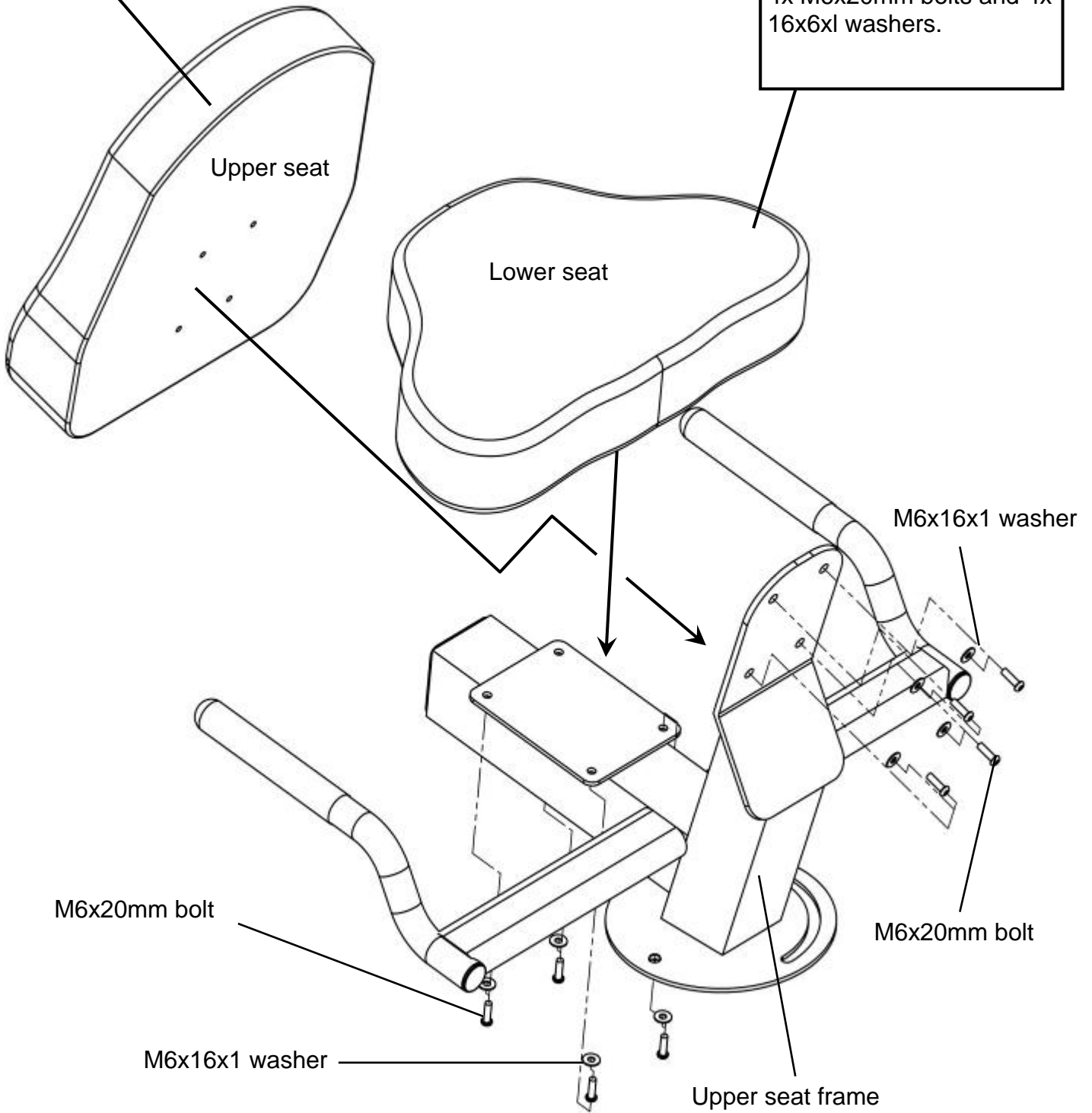

E720 Assembly Instructions

Step 3: Attach lower seat to lower mainframe using 4x M10x25mm bolts, 4x M10 Nylock nuts and 8x 21x11x2 washers

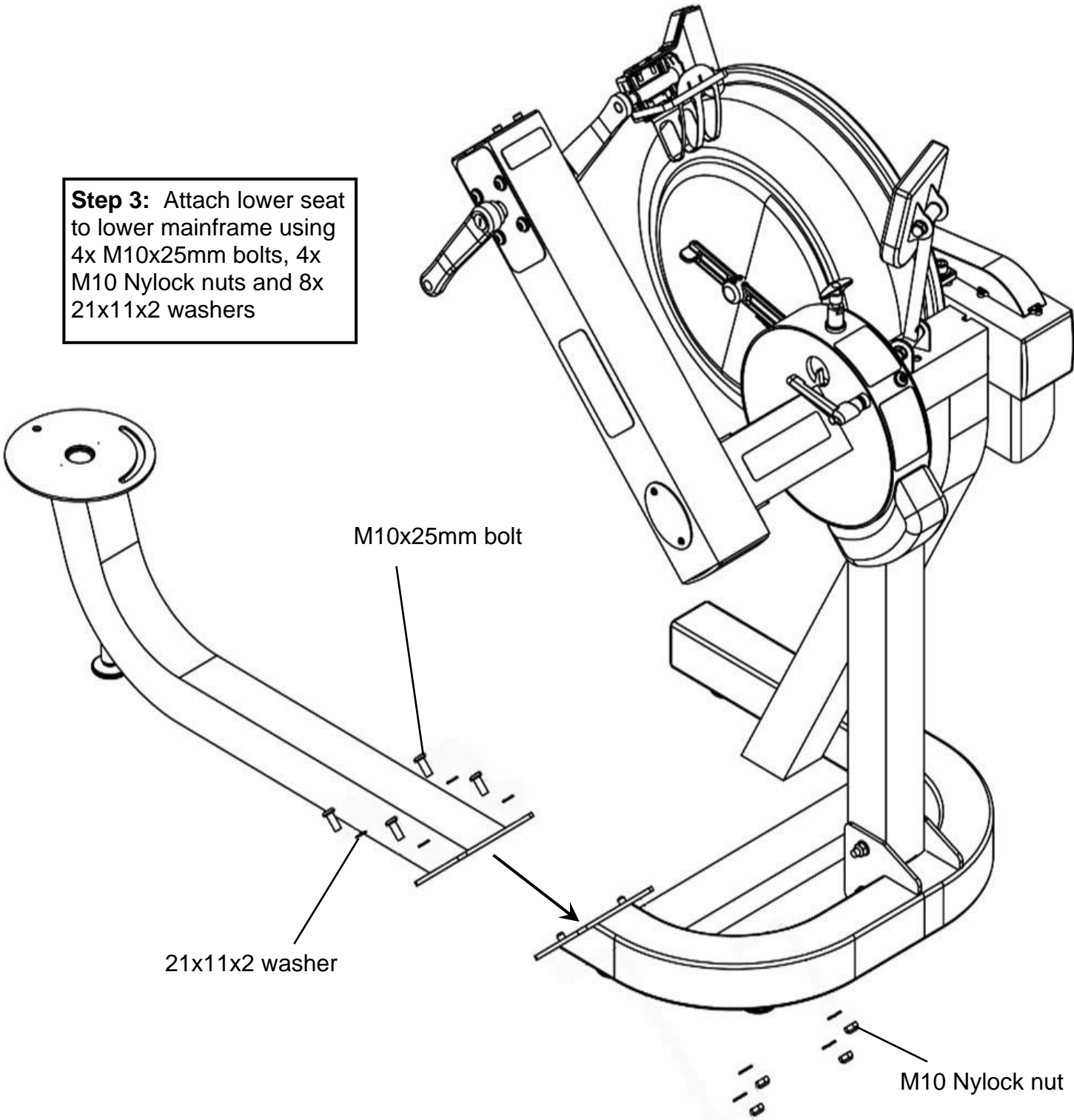

E720 Assembly Instructions

Step 4: Lower upper seat frame onto lower mainframe and secure using 1x M10x25mm bolt, 1x M10 Nylock nut, 3x 21x11x2 washers and L-pin.

Note: Tighten the M10x25mm bolt, washers and Nylock until lightly snug only. Over-tightening will prevent the seat from rotating. Use the L-pin to tighten the upper seat frame once rotated into place.

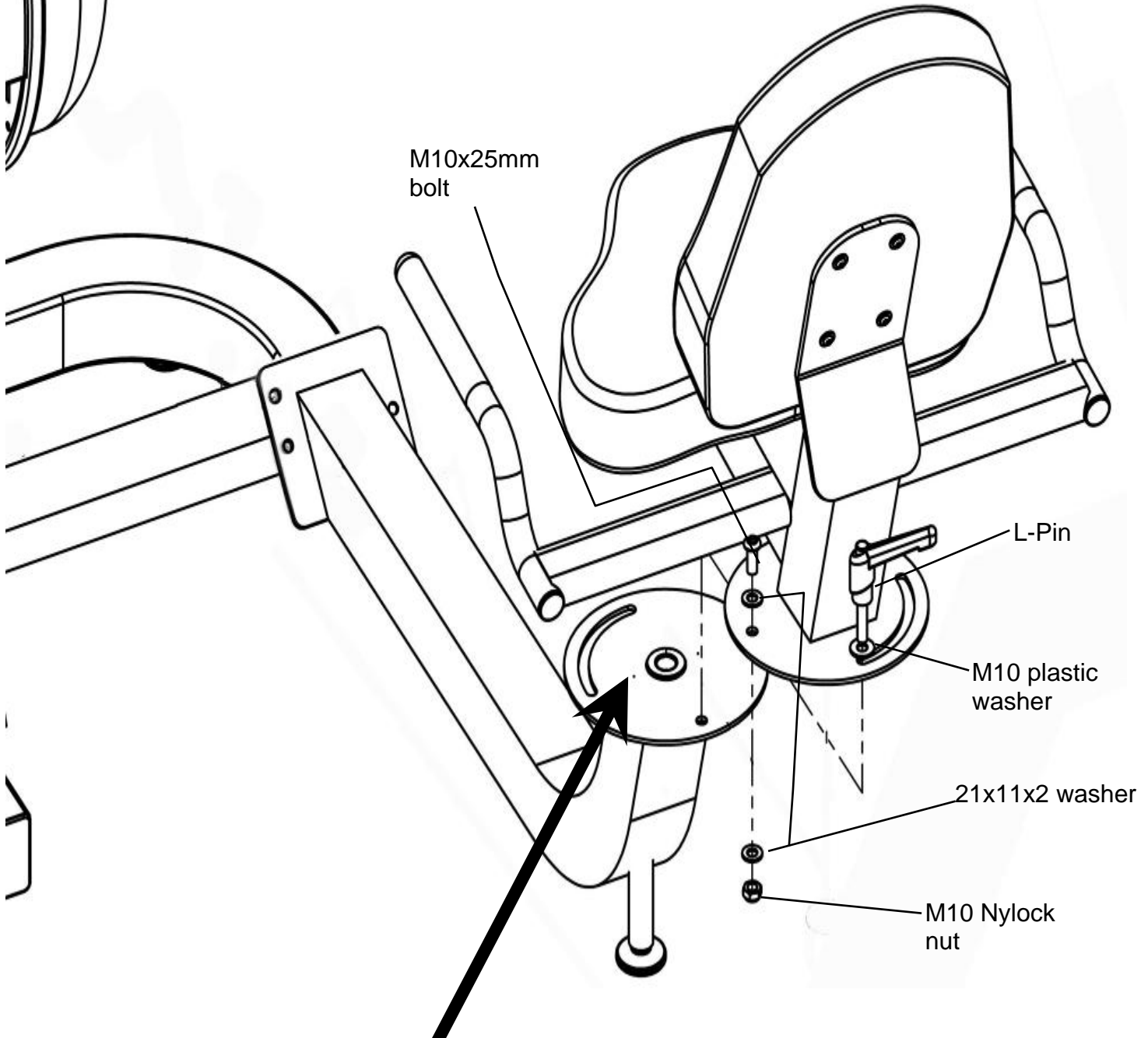

Before installing the upper seat frame onto the lower, use the supplied grease and apply liberally between the two sliding surfaces

E720 Assembly Instructions

Note: Allow 15 minutes for the thread-locker to activate before first time use.

Check pedal tightness on a regular basis and tighten as needed with a 15mm wrench.

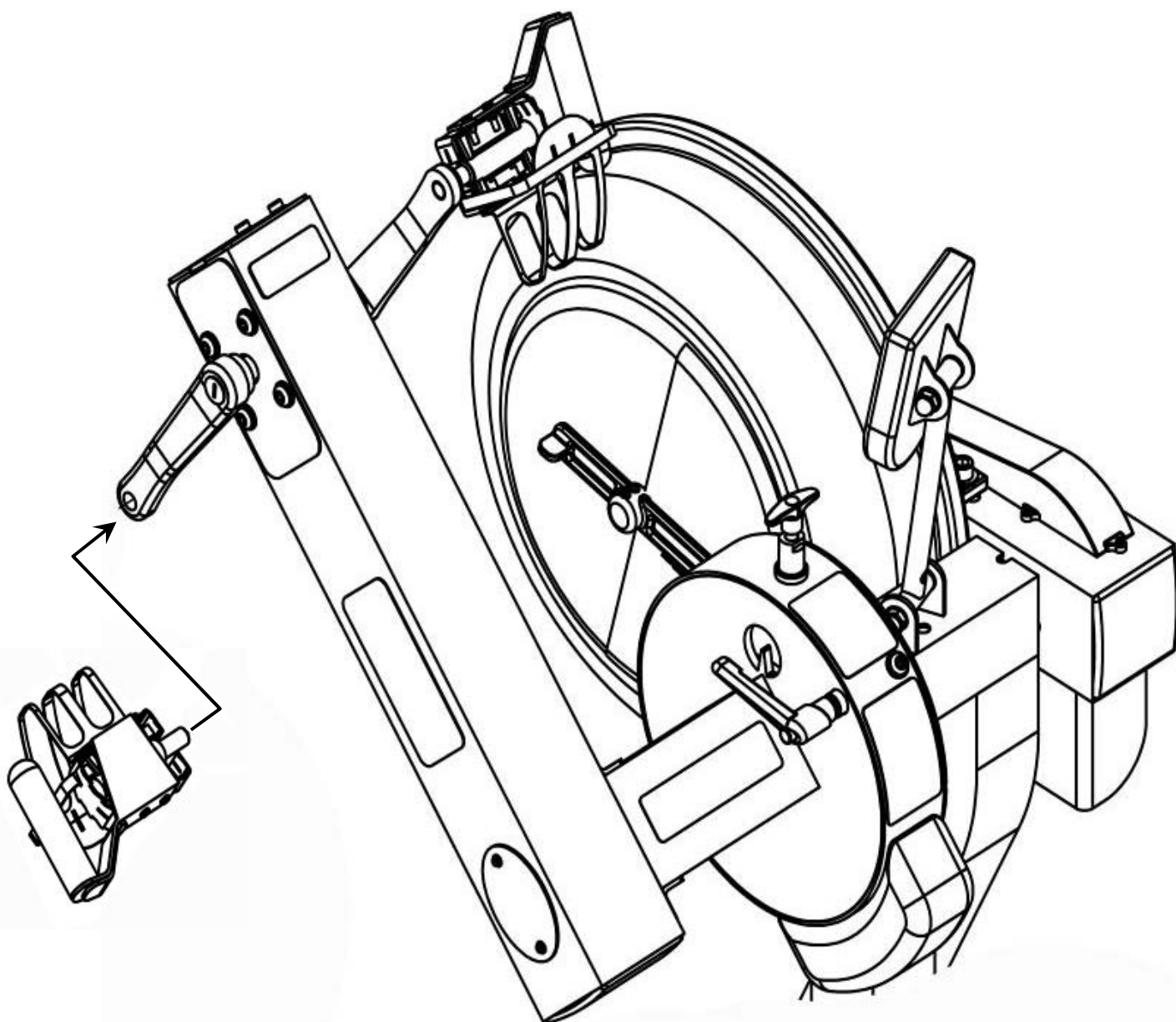

Step 5: Secure right pedal onto Crank arm. The pedal threads have a blue coating which will feel very tight when threaded onto the crank arm. This is a type of thread locker, and once in contact with the crank arm threads will activate in approximately 15minutes.

Caution! Extreme over-tightening could damage the aluminum threads on the crank arm.

Tank Filling and Water Treatment

Note: A large bucket is required for filling (Not included).
In areas where tap water quality is known to be poor, FDF recommends the use of distilled water.

Open the tank plug and insert hose into tank (rotating the impeller slightly may be necessary to allow the hose to pass), move the tank adjuster handle to level 20 and begin filling. Do not fill the tank higher than the level indicator on the front of the clear shell. A properly filled tank holds approximately 8 liters of water.



WARNING

Do not under any circumstances put fingers into the tank. Use the end of the hose to move the impeller should the need arise.

Water Treatment Procedures:

1. Add Chlorine tablet.
2. Enough Chlorine Tablets are supplied for many years of Water treatment. Add a chlorine Tablet whenever the Water appears dirty or cloudy.

WARNING: Only use First Degree Fitness Supplied Water treatment tablets.



Caution:

Use a drop cloth under the tank when filling the tank to avoid damage floor or carpet

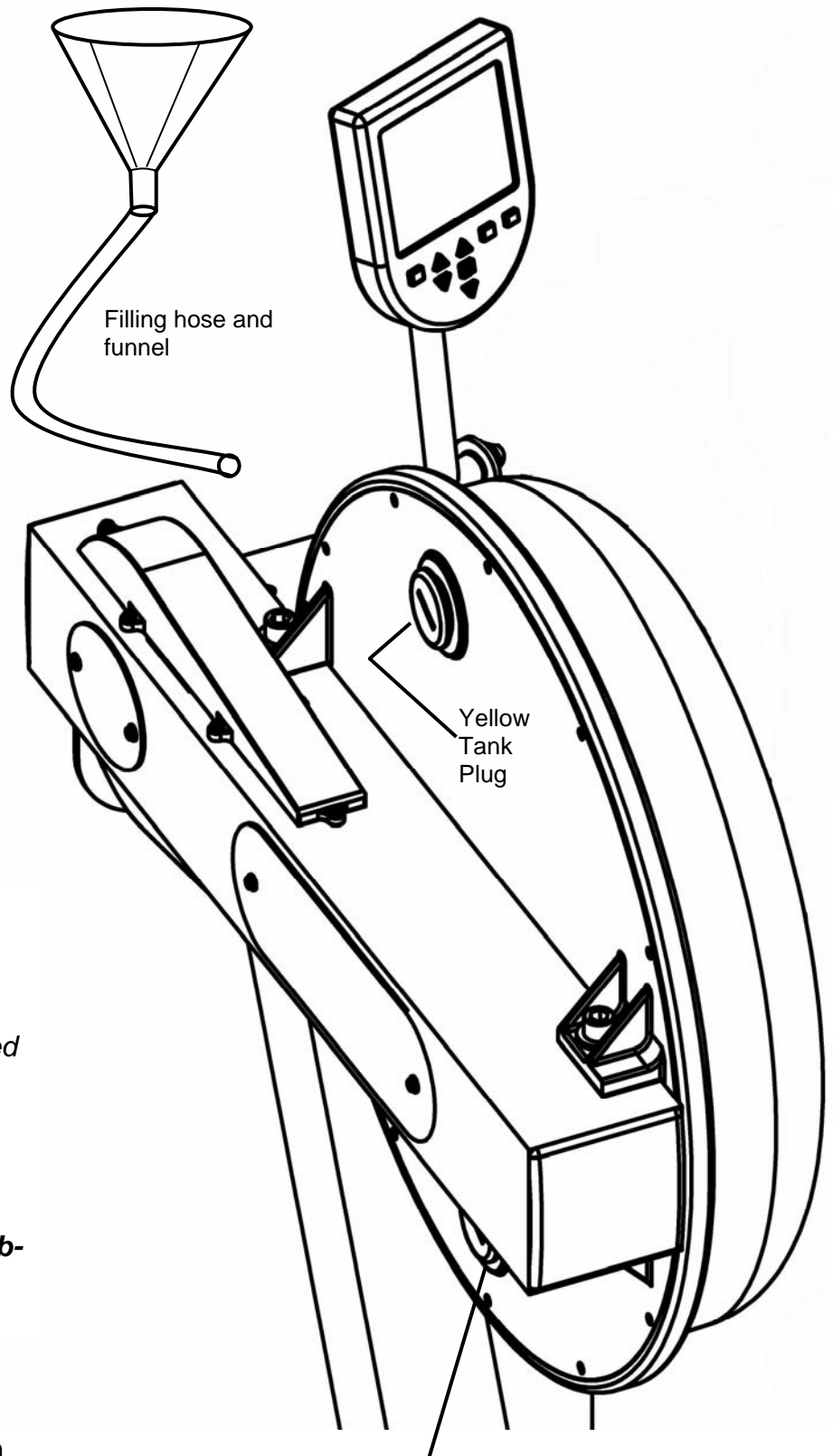

Note: Lower tank plug is permanently sealed.

Long Term Water Treatment and Basic Operation



CAUTION

Important: Do not fill past the calibration mark as indicated on the tank level sticker or water spillage may occur. See tank filling and water treatment page for details.

Long term water treatment:

Do not use any water treatment other than the tablets supplied with this machine. For replacement tablets, contact your local First Degree Fitness distributor or visit www.firstdegreefitness.com for distributor locations.

Water treatment schedules for the E720 will vary according to the fluid tanks exposure to sunlight but expect 8-12 months near a bright, sunlit window and 2-4 years for a darker location. At the point of finding the water slightly green, add a Chlorine tablet. Remember to wait 72 hours before adding the blue dye as the Chlorine tablet is extremely concentrated.



Caution: It is important that a drop cloth be used under the fluid tank whenever the tank plug is opened for water treatment.

Resistance:

The level of resistance is determined by the level indicator located on the front of the tank. Level one indicates lightest resistance, level twenty represents heaviest resistance. Allow three to four seconds after adjusting resistance handle for the correct resistance level to be achieved.

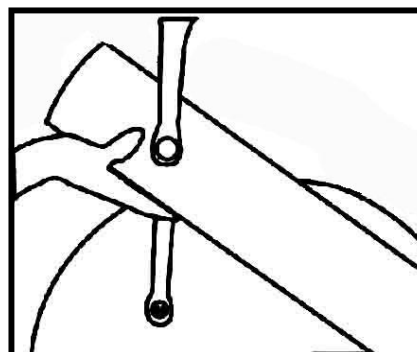
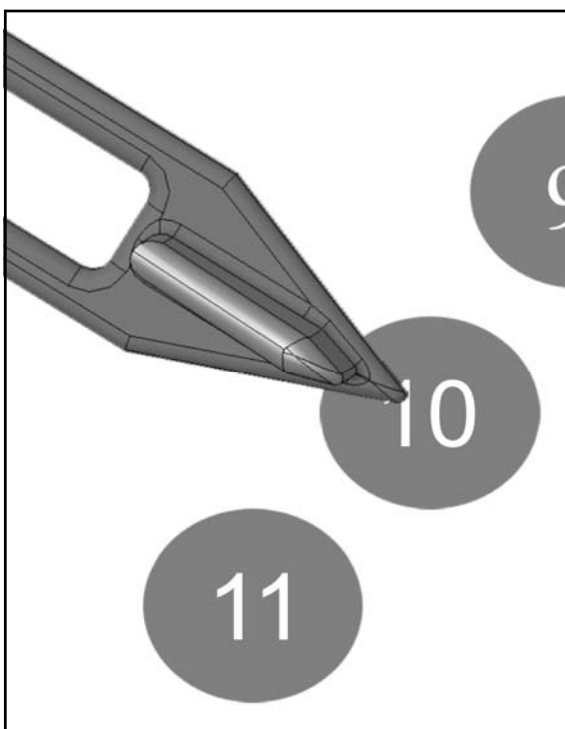

Warning:



Removing hands before the crank comes to a complete stop while training can cause injury. The crank is direct drive so as to allow both forward and reverse rotation during workouts.

The E720 Control Arm

Chain tensioning bolts: Allows for tightening the chain or adjustment from side to side. Make sure when tightening only to adjust the same amount for both bolts, otherwise the sprocket will be mis-aligned.

Note: Tightening the right bolt only will pull the right side of the crank assembly toward you, tightening the left will pull the left side toward you. Use this feature to realign the rear with the front sprocket if needed or when changing to a new chain.

Crank arm bolts:
Loosen all 8 bolts slightly before adjusting/tightening chain.

T-pin: The T-pin locks the control arm in any one of 72 different positions throughout its 360 degree range of motion. Pull up the T-pin to allow the control arm to rotate while supporting the control arm with the other hand.

The E720 Pedal: This patented design allows for usage in both the recumbent position and for sitting/standing upper body workouts.

Inspection plate: Open to check chain tension.



Warning: Do not check chain tension by hand!

L-pin: Loosen when rotating the control arm and tighten (snug only) once the desired position has been reached.

Maintenance chart.

Item	Timeframe	Instructions	Notes
Seat and Frame.	Weekly.	Wipe down weekly with lint free cloth or more often with heavy club use.	
PK belt tension.	Monthly.	Check monthly for signs of slippage. Adjust/ tighten as required.	
Tank and water treatment.	12 months to 2 years.	Follow instructions as specified in the "Water Treatment" section of this manual.	
Chain drive.	Check every 100 hours for correct tension.	Open the inspection plate and check tension using a screwdriver or other tool. Tighten as required using chain tensioning bolts located at the end of the control arm.	
E720 pedals.	Tighten weekly using 15mm box wrench (supplied)	The pedals should be checked on a regular basis. A loose pedal can cause damage to the crank arm aluminum threads, requiring replacement.	

Troubleshooting guide:

Fault	Probable Cause	Solution
Water changes color or becomes cloudy.	Rower is in direct sunlight or has not had water treatment.	Change rower location to reduce direct exposure to sunlight. Add water treatment or change tank water as directed in the water treatment section of this manual.
Knocking noise from inside the control arm while training, especially when changing directions.	Chain requires tightening or adjustment.	Open inspection plate located on front of control arm and check tension using a screwdriver or other tool. Use the chain tensioning bolts located at the rear of the control arm to tighten or adjust as needed. The chain should have approx 3mm of slack when properly adjusted. See P.10 for details.
Pedals slip during hard training.	PK tank belt requires tightening.	Remove large inspection plate next to the tank, insert a long tool to push the rear end cap out from the inside, exposing the tank belt tensioning bolt. Loosen tank bolts slightly. Remove upper rubber belt cover to expose the PK belt. Tighten the tank tensioning bolt until the belt is too tight to be twisted from side to side more than 45 degrees by hand. See P.14 for details
Pedal is loose (either left or right) and cannot be retightened.	Aluminum crank arm threads are stripped.	Contact service center for replacement. Then check weekly as recommended.
Computer screen illuminates, but does not register when rowing.	Loose or failed connection/Sensor gap too wide (see erratic computer display).	Check that the computer lead is connected properly. If connected properly check sensor gap. Contact your local service center if this fails to address the problem.
The E720 computer does not illuminate after battery installation.	Batteries installed incorrectly or need replacing.	Reinstall batteries in correct position and try again. If the LCD screen fails to illuminate, try rotating the batteries slightly in the computer. If this fails, contact your local service center.
The E720 computer display is erratic/slow while displaying RPM and WATTS	Gap between sensor and magnetic ring is too wide.	Remove inspection plate and check sensor gap and that magnetic ring is not wobbly.

E720 Ergometer.

Quick start provides instant workout information. Just start training to activate. You can choose to change UNITS displayed.

Note: For complete operational instructions, please refer to the computer manual, which is included with your E720.

The diagram shows the Fluid E720 Ergometer console with the following callouts:

- UNITS displays**: Points to the top left of the display area, listing WATTS, RPM, HR, MPH.
- Reset Clears data**: Points to the RESET button.
- Program Clears current exercise program**: Points to the PROGRAM button.
- Set Changes Time, Distance parameters**: Points to the SET button.
- Level Adjustable from 1-20**: Points to the LEVEL controls, which include a numeric display (10 and 11) and a pencil icon.

The console display shows the following information:

- Quick Start Pacer Interval Workout**: Main workout mode.
- WATTS 500/M HR**: Power and heart rate.
- 0.0:0.0**: Time display.
- KPH MPH SPM RPM**: Speed and cadence units.
- Pacer**: Pacer mode with a fan icon and a time display of 8.8.8.
- Workout Intervals**: Workout segments (1 2 3, 4 5 6) and interval times (88:88).
- Time 8:88:88**: Total workout time.
- Level 88**: Current level setting.
- Dist 88.888 KM MLS FLS**: Distance in kilometers, miles, or furlongs.
- Speed 88:8.8 KPH MPH FPM**: Speed in kilometers per hour, miles per hour, or feet per minute.
- Heart Rate 888 HR**: Heart rate in beats per minute.
- Rate 888 SPM RPM**: Rate in strokes per minute or revolutions per minute.
- Watts 888**: Power output.
- Cals 8888**: Calories burned.

The control panel includes buttons for UNITS, LEVEL (+/-), SET, PROGRAM, and RESET. A QUICK START button is also present with the instruction: "Press any button or start exercise".

Using the First Degree Fitness USB Interface

Description:

The USB connectivity now built in to all new models of FDF Console and IPM allow you to enhance your exercise experience by connecting to your home PC or Laptop. Using FDF's own sample applications you can exercise while enjoying your favorite movies. *NetAthlon 2 XF for Rowers* lets you race with other Internet connected rowers in a Virtual Reality 3D environment or train solo.

Setting up USB connectivity

1. Download and Install the USB Device Driver (CDM2xxxx_Setup.exe for 32 and 64 bit Windows 7/Vista/XP) from the FDF Website.
2. Download and Install the Sample USB Applications from the FDF Website (www.firstdegreefitness.com).
Download and Install NetAthlon 2 XF for Rowers from <http://www.webracing.org/downloads.htm>

Connecting your

- The USB Connector is located on a flying lead at the rear of the IPM, along with the Sensor and Heart Rate Monitor Connectors.
- Connect to a Laptop or PC using a standard USB cable, you may need to wait while Windows starts the USB Device Driver.

Note: Please refer to computer manual where applicable or for further information refer to our website at www.firstdegreefitness.com

Tank Belt Adjustment

Step 1: Remove large metal inspection plate as shown above right.

Step 2: Using a long tool, push out the rear end cap as pictured right. This will give you access to the tank tensioning bolt (shown bottom right).

Step 3: Loosen both the front and rear tank bolts as shown below. Remove front rubber belt cover.

Step 4: Using a 6mm Allen key, tighten the belt using the tank tensioning bolt until the belt no longer slips during hard rowing.

Note: Do not over tighten tank bolts.

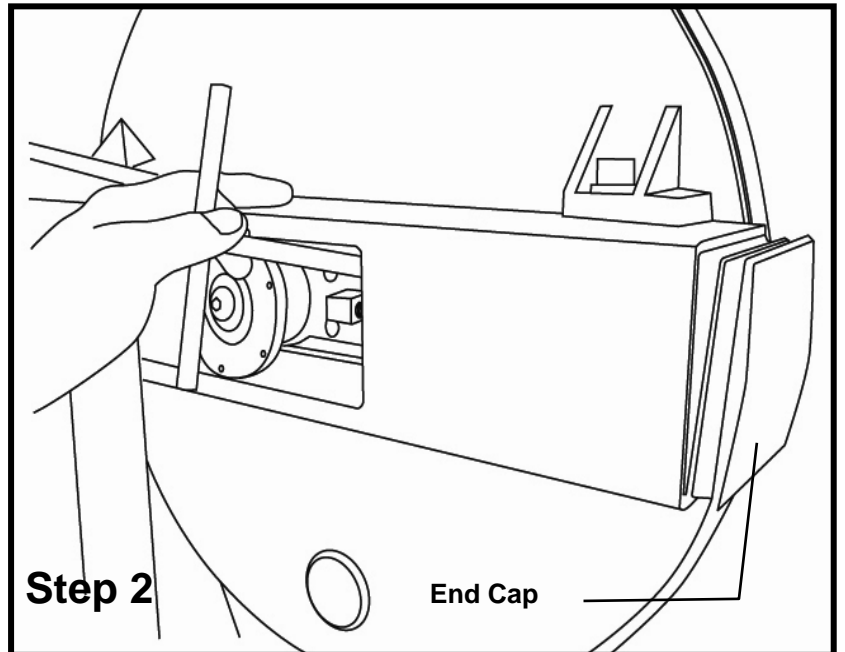
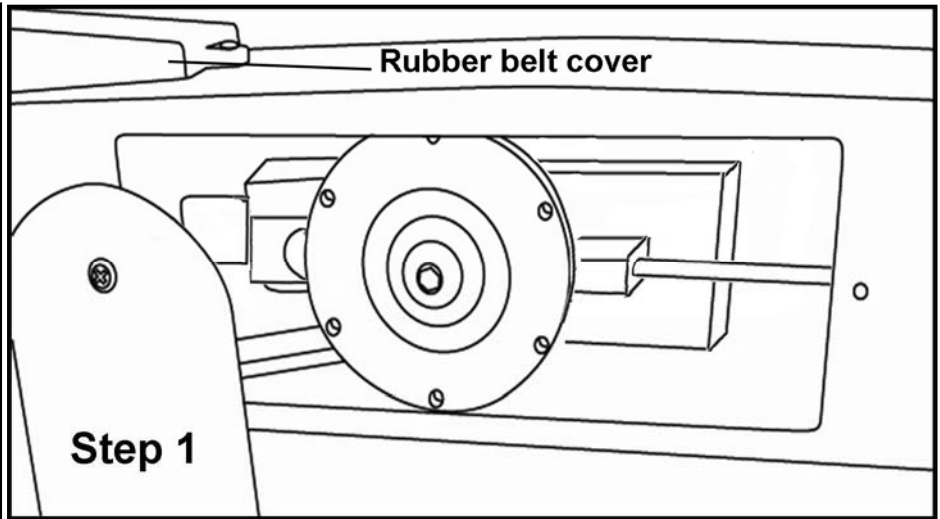

Tip: Twist the belt by hand to gauge tightness. Correct tension should be obtained when no longer able to twist more than 45 degrees.

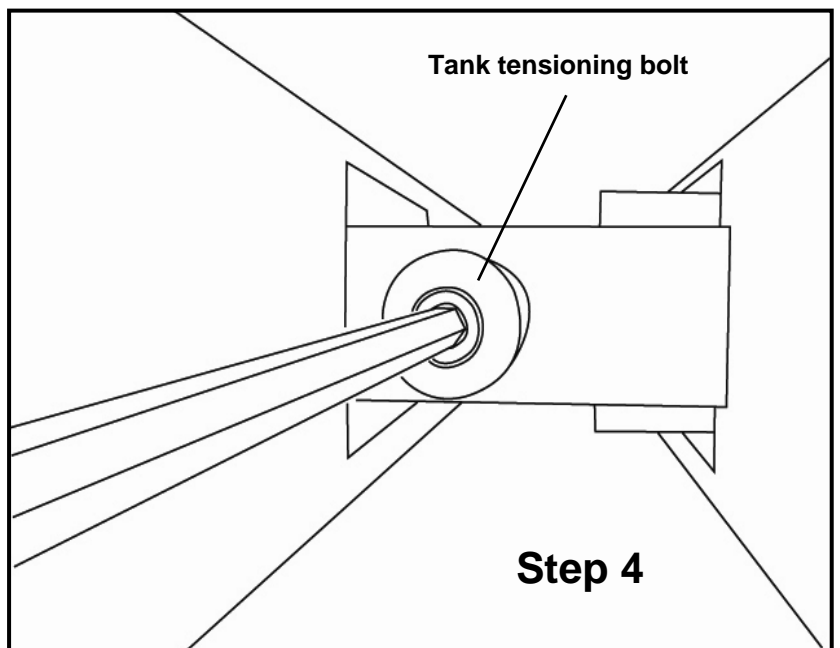
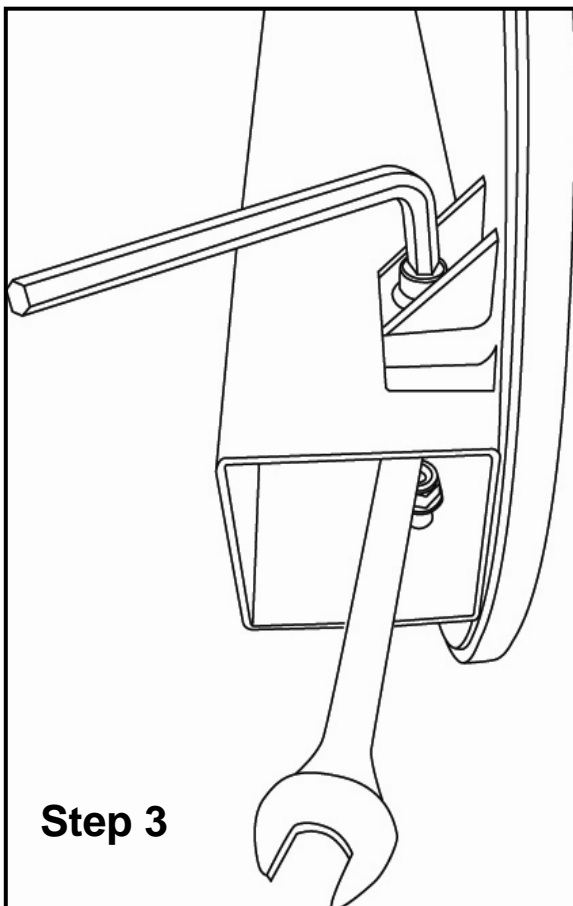

E720 Exploded Diagram:

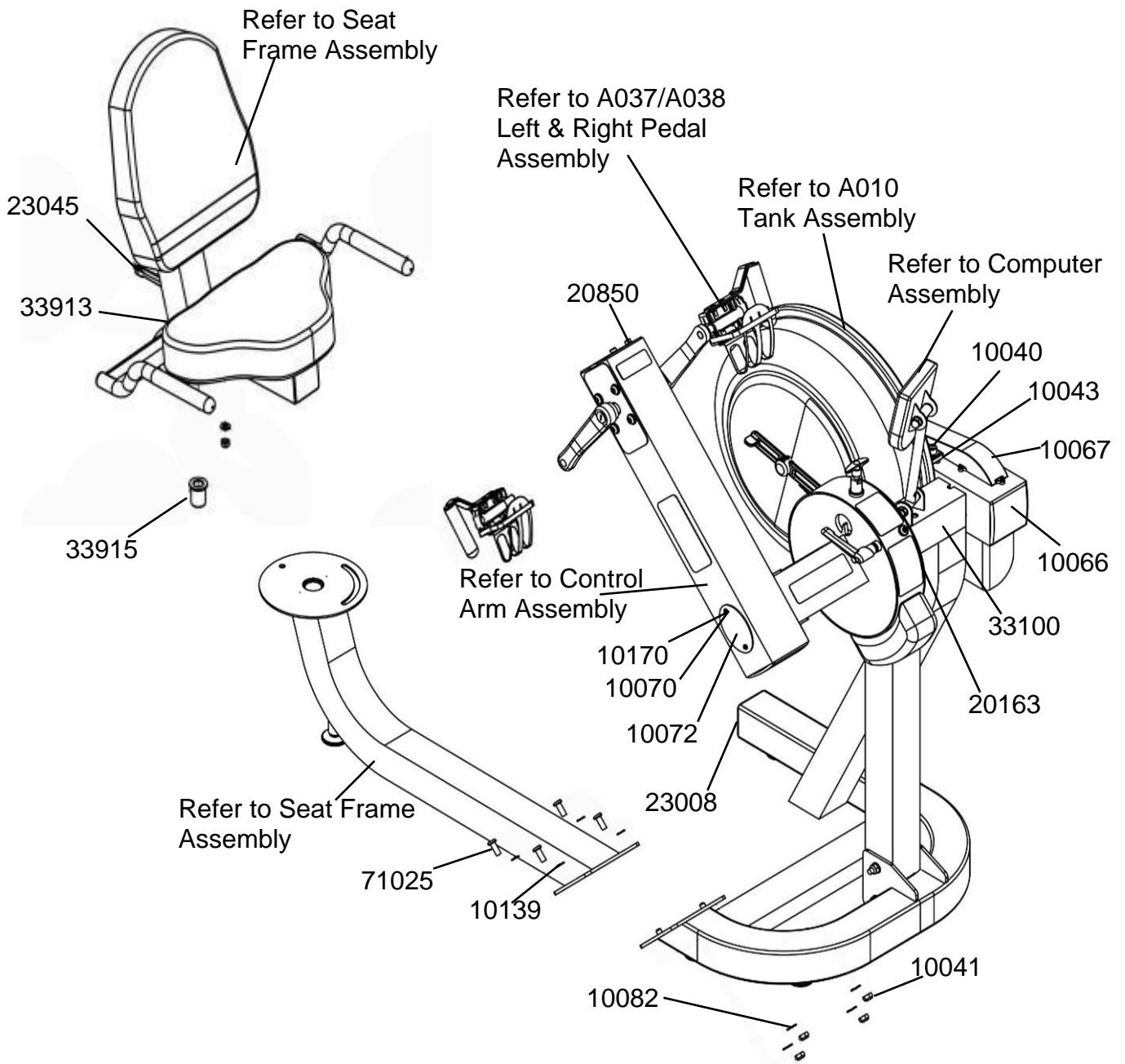

P/N	QTY	Description	P/N	QTY	Description
10040	1	Bolt M12x140	10170	6	Washer M4
10041	6	Nut M10 Nylock	23008	1	End Cap 75x75 Rubber
10043	6	Washer M12	20163	2	Semi Circle Cover
10066	3	End Cap 100x100mm	20850	1	Tension Adjustment
10067	2	Rubber Cover for Large PK Pulley	23045	1	L Pin M10x35
10070	18	Screw M4x10	33100	1	Main Frame Assembly
10072	2	Small Steel Side Cover 100mm	33913	1	Plastic Spacer 10x25x4T
10082	9	Washer M10	33915	1	Oil Bushing
10139	2	Spring Washer Flywheel Shaft	71025	2	M10x25mm Main Shaft Rear Bracket Bolt

Upper/Lower Mainframe:

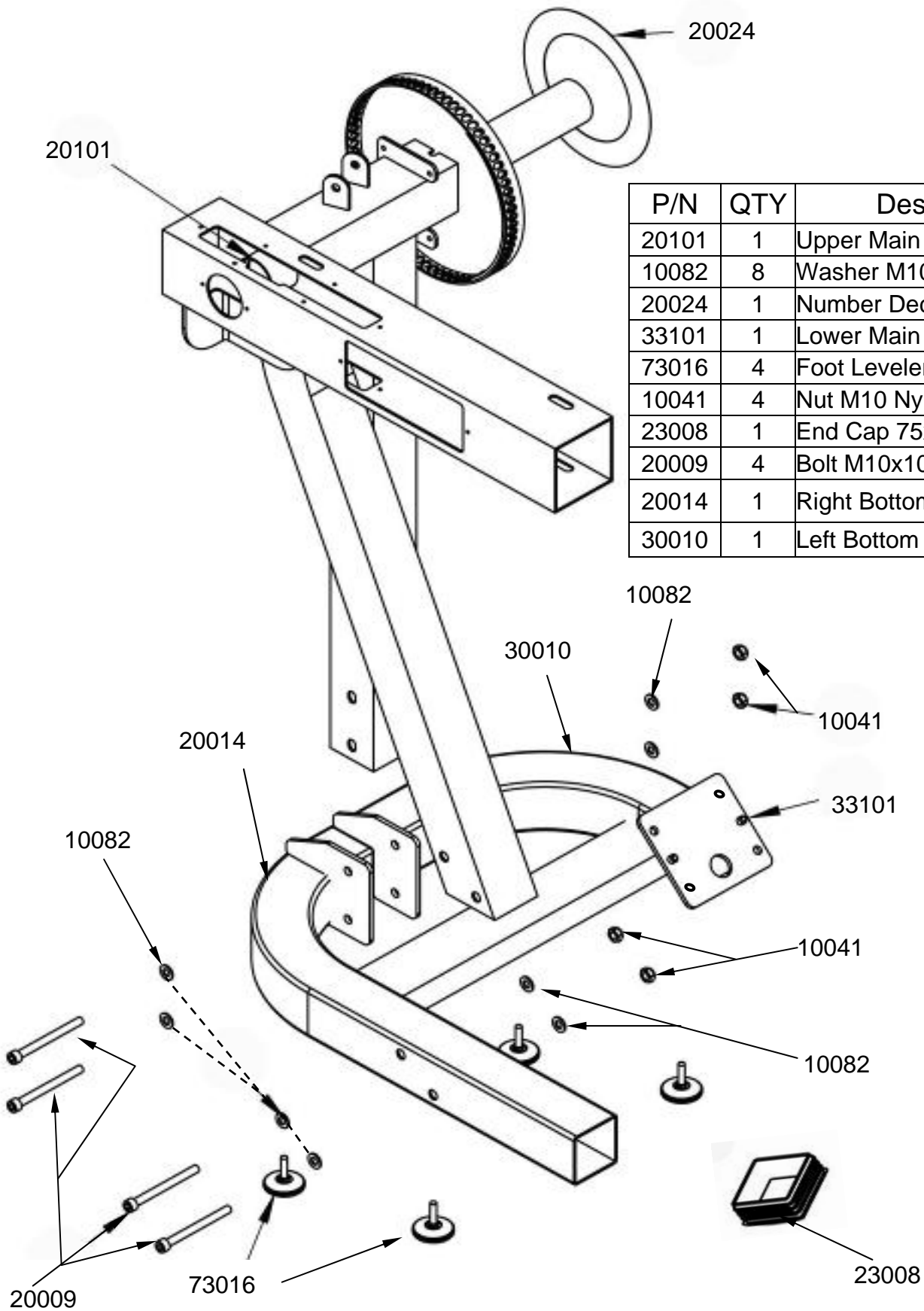

P/N	QTY	Description
20101	1	Upper Main Frame
10082	8	Washer M10
20024	1	Number Decal
33101	1	Lower Main Frame
73016	4	Foot Levelers M8x30 PVC
10041	4	Nut M10 Nylock
23008	1	End Cap 75x75 Rubber
20009	4	Bolt M10x100
20014	1	Right Bottom Frame
30010	1	Left Bottom Frame

Control Arm (external) Assembly:

P/N	QTY	Description
30012	1	DID-25 Chain 178
10066	1	End Cap 100mm
10170	2	Washer M4
10070	2	Screw M4x10
20163	2	Semi Circle Cover
20850	1	Tension Adjustment

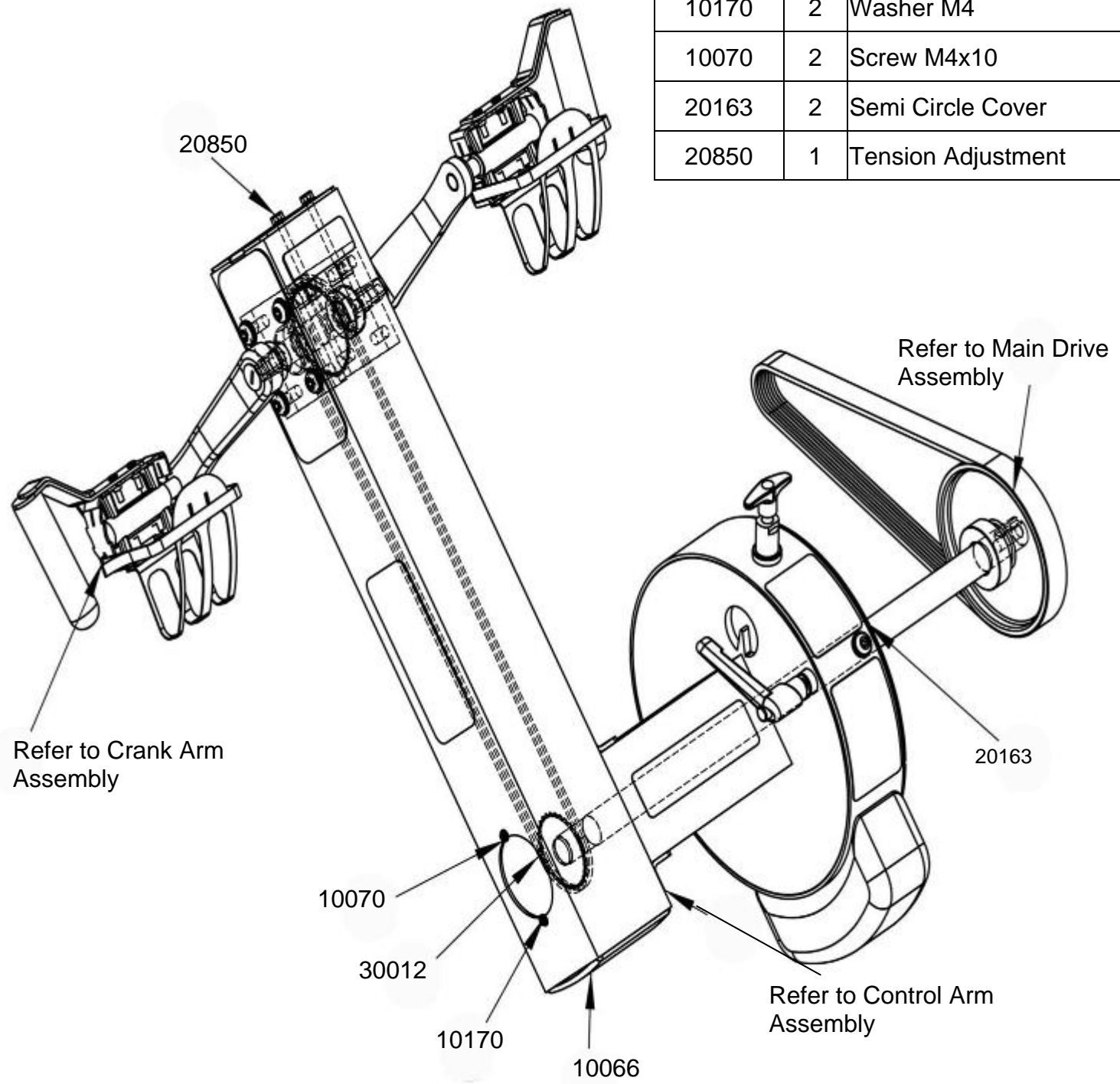

Seat Frame Assembly:

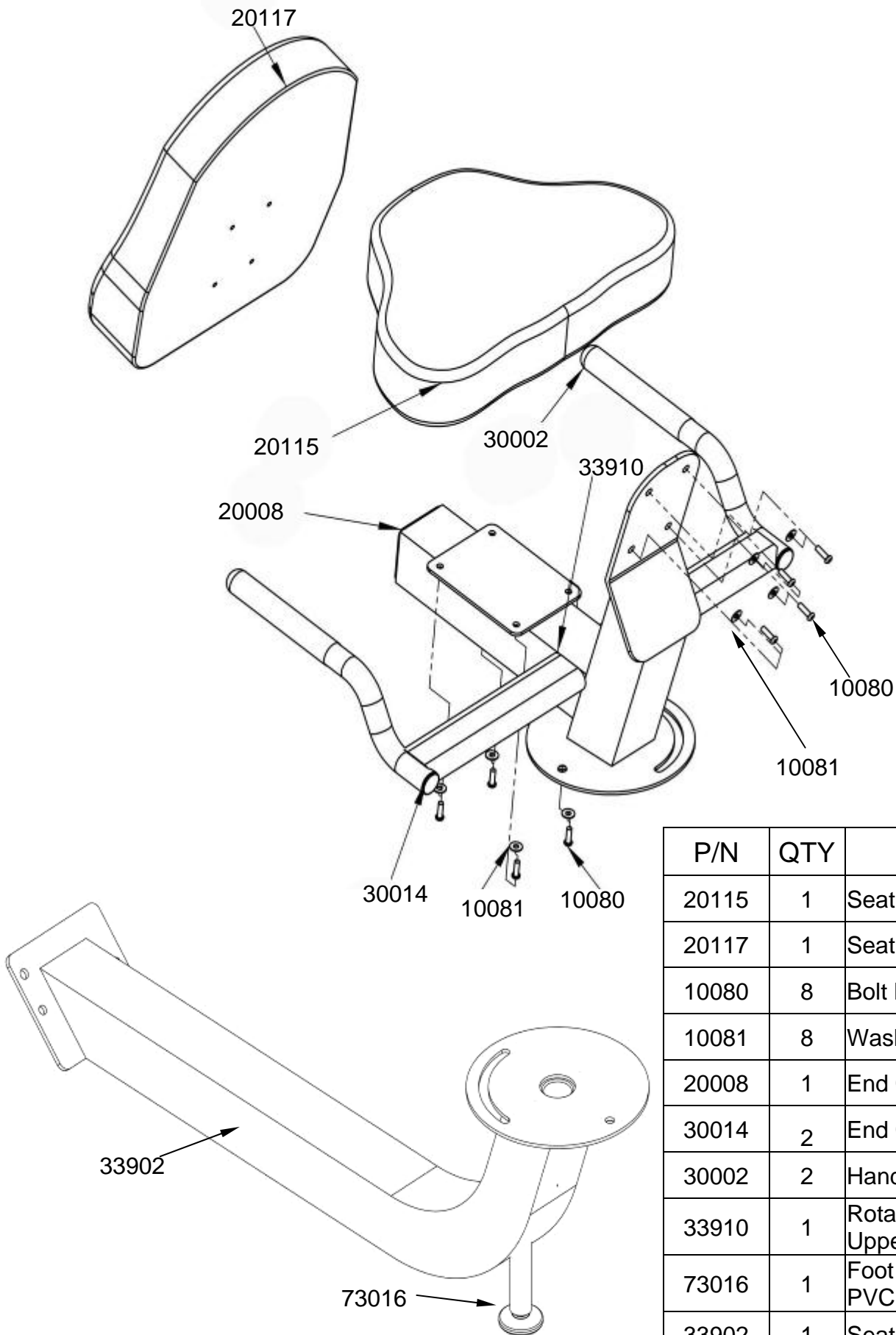

P/N	QTY	Description
20115	1	Seat LS-622
20117	1	Seat Back LS-622
10080	8	Bolt M6x20
10081	8	Washer M6
20008	1	End Cap 75x75 PVC
30014	2	End Cap
30002	2	Handle Grip
33910	1	Rotating Seat Frame Upper
73016	1	Foot Levelers M8x30 PVC
33902	1	Seat Lower Frame

Computer Assembly

P/N	QTY	Description
13112	1	Computer Mounting Arm
10114	4	Bushing 20x16x13x10
10082	4	Washer M10
10116	1	Bolt M10x60
10097	2	Nut Dome Head M10
10117	1	Computer Wiring 1200
10096	1	Bolt M10x70 for Aluminum Rail
50903	1	Computer

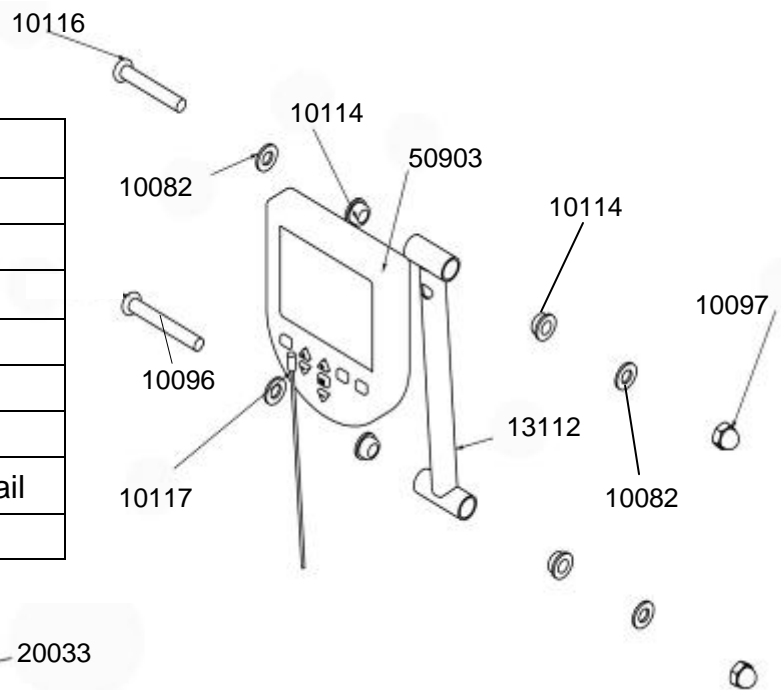

Control Arm Assembly

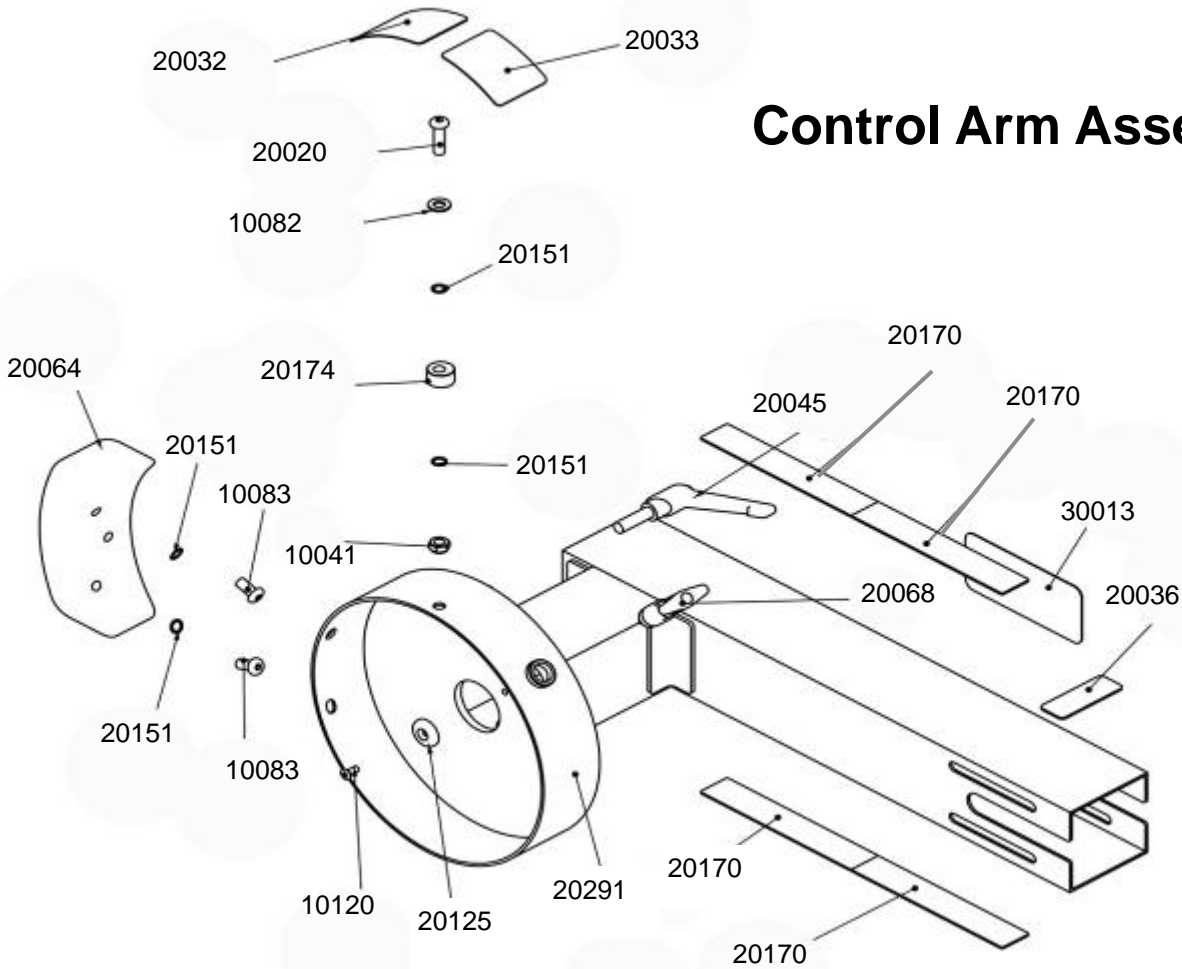

P/N	QTY	Description	P/N	QTY	Description
10041	1	Nut M10 Nylock	20045	1	L-Pin M12x40
10082	1	Washer M10	20064	1	Weight Block
10083	2	Bolt M10x20	20068	1	T-Pin
10120	1	Screw M6x15	20125	1	Plastic Washer 30*6*6
20020	1	Bolt M10x35	20151	4	Washer M10
20032	1	Warning Decal	20170	4	Chain Protection Decal
20033	1	Arm Moving Decal	20174	1	Eccentric Bushing
20036	1	Small Warning Decal	20291	1	Rotating Arm
			30013	1	CXT Decal

Main Drive Assembly

P/N	QTY	Description	P/N	QTY	Description
10011	1	Bearing Housing	10083	1	Bolt M10x20
10012	1	NSK 6005ZZ Bearing	10109	1	Belt 7PK 926mm HUTCHINSON
10015	1	Large PK Transmission Pulley 150mm	10138	1	Shaft Washer 30x10.2x3t for Fly-wheel, Stainless
10017	1	Key way 7x7x32	10139	1	Spring Washer M10 for Impeller
10052	1	Grub Screw M4x6	10146	1	Ball Bearing NSK6006ZZ
			20157	1	Shaft+Sprocket—E720

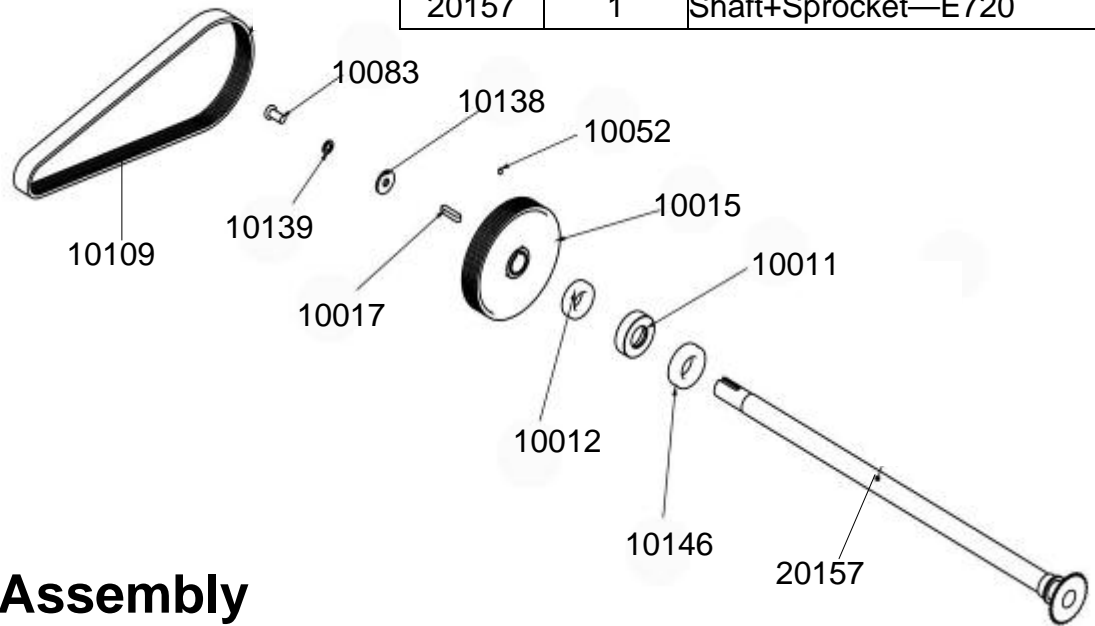

Crank Arm Assembly

P/N	QTY	Description	P/N	QTY	Description
10082	8	Washer M10	20135	1	Crank-Right
20020	8	Bolt M10x35	20190	2	Aluminum Block Bearing Housing
20052	2	Side Bearing Cover	20193	2	NSK 6004ZZ Aluminum Block Housing Bearing
20132	2	France Screw M8x20xP1.0	20196	2	Wave Washer 20mm
20133	2	Crank End Cap	30610	1	Cycle Axle + Cog
20134	1	Crank-Left	30611	1	Right Pedal Assembly

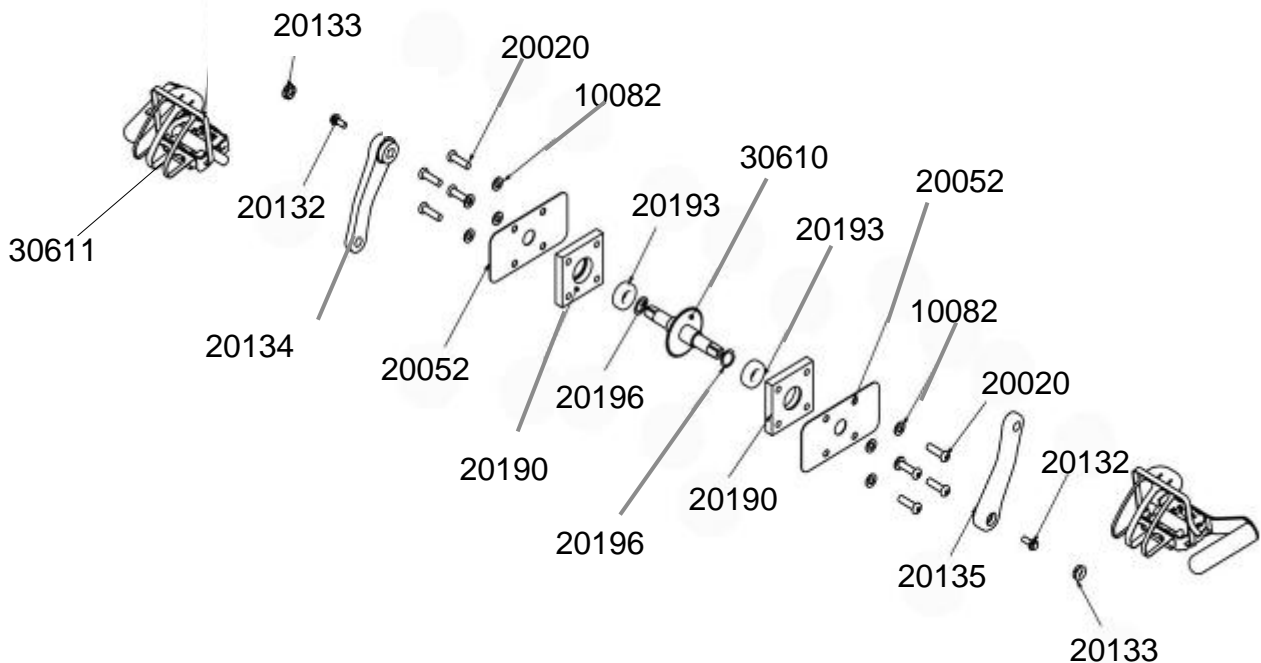

A010 Tank Assembly

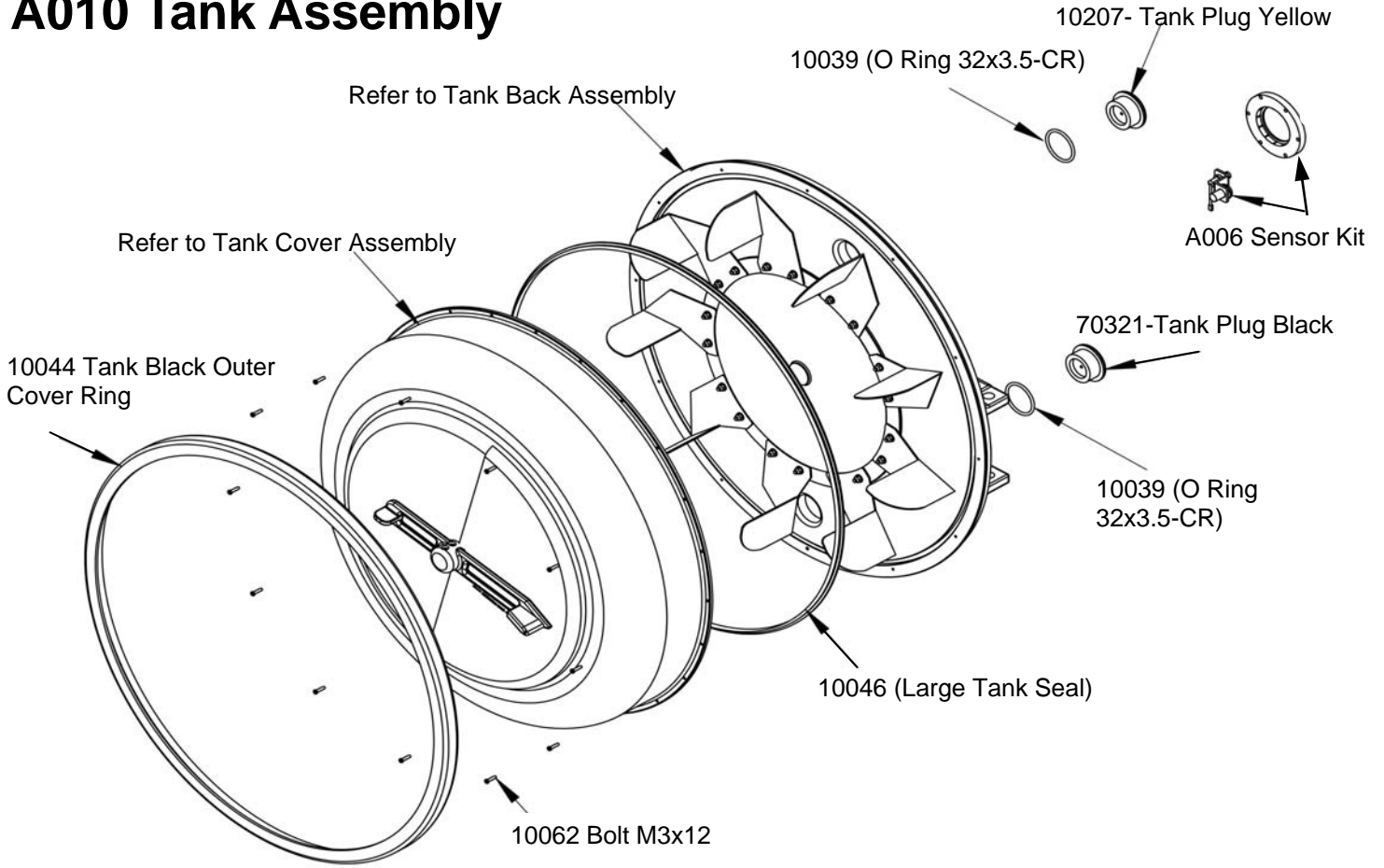

A053 Flywheel Assembly E720/820/920

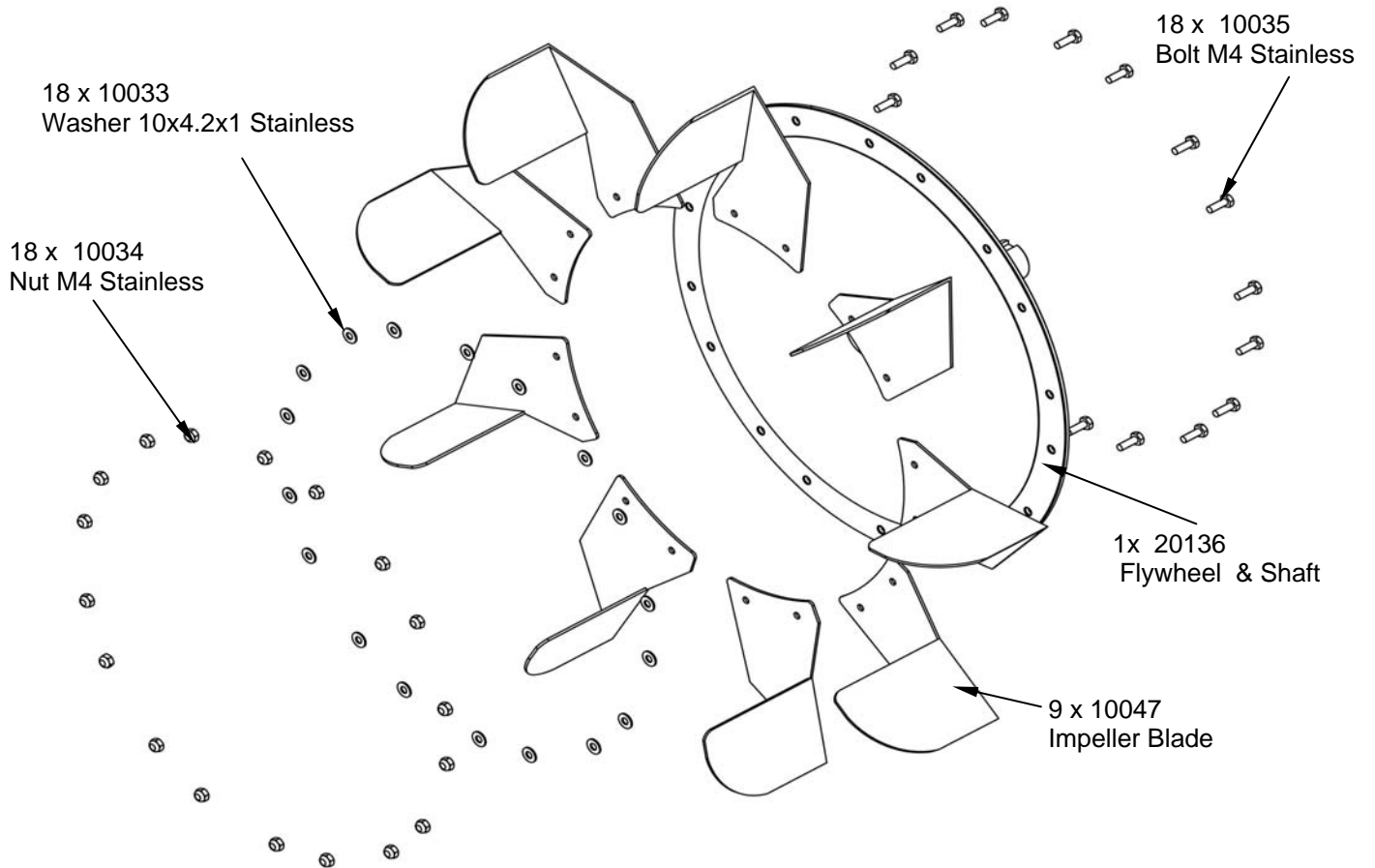

A012 Tank Bearing & Seal Kit

P/N	Description	QTY
10012	Bearing NSK 6005ZZ	2
10025	Seal NBR 37x30x8t for Flywheel Shaft	1
10145	Bearing Spacer 30x25.1x20.5mm	1
10186	C Clip RTW-48	1

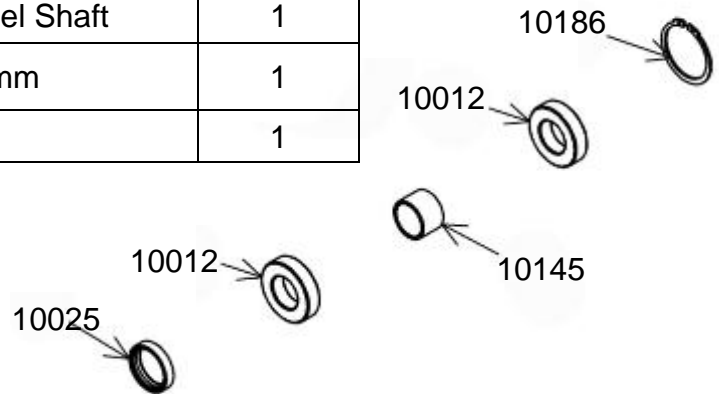

A013 Tank Back Kit

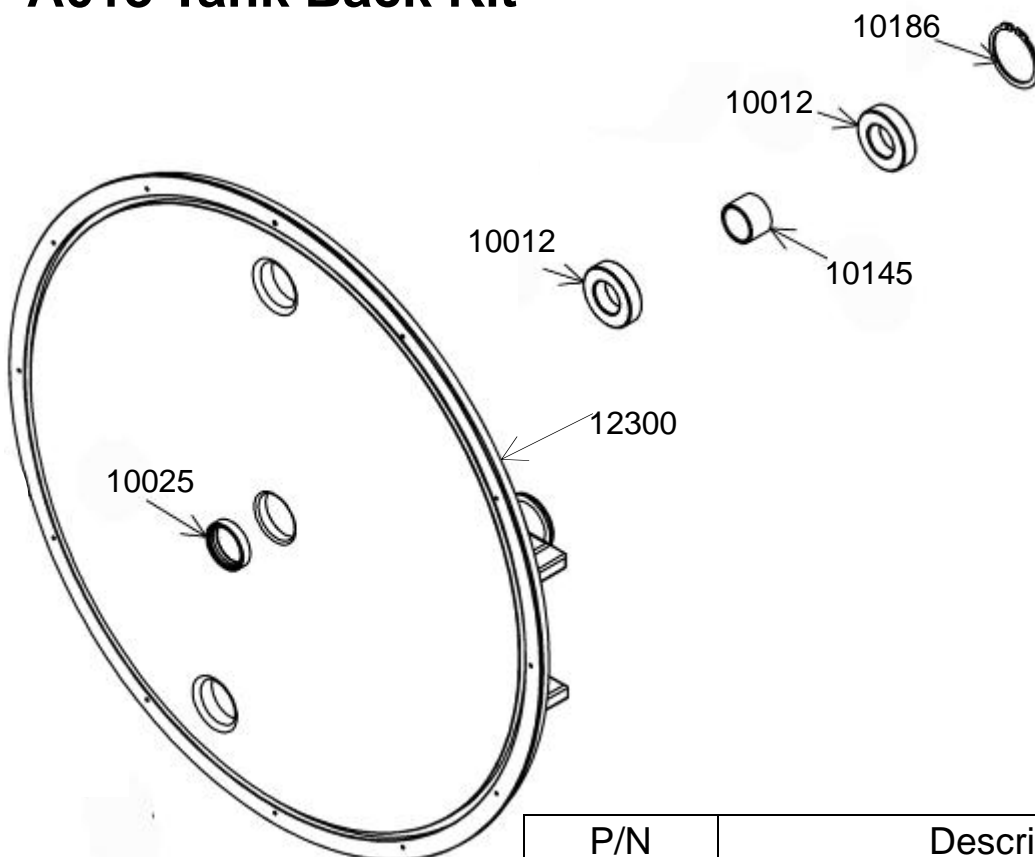

P/N	Description	QTY
10012	Bearing NSK 6005ZZ	2
10025	Seal NBR 37x30x8t for Flywheel Shaft	1
10145	Bearing Spacer 30x25.1x20.5mm	1
10186	C Clip RTW-48	1
12300	SMC Tank Back—Gray	1

Tank Cover Assembly

P/N	QTY	Description
10027	1	Adjuster Handle Shaft
10028	1	Stainless 0.8mm Backing Plate
10030	1	Blue Adjuster PP Tank Ring
10032	2	Adjuster O Ring 12x9x1.5
10033	4	Stainless Washer 10x4.2x1
10034	4	Nut M4 Stainless
10035	4	Bolt M4 Stainless
10036	12	Screw M3x20mm for Blue Tank Ring
10059	1	Level Decal 20R
10162	2	M8x10 Grub Screw
10184	1	Tank Level Resistance Handle
10193	1	PU Cover for Resistance Handle
13345	1	PC Tank Cover

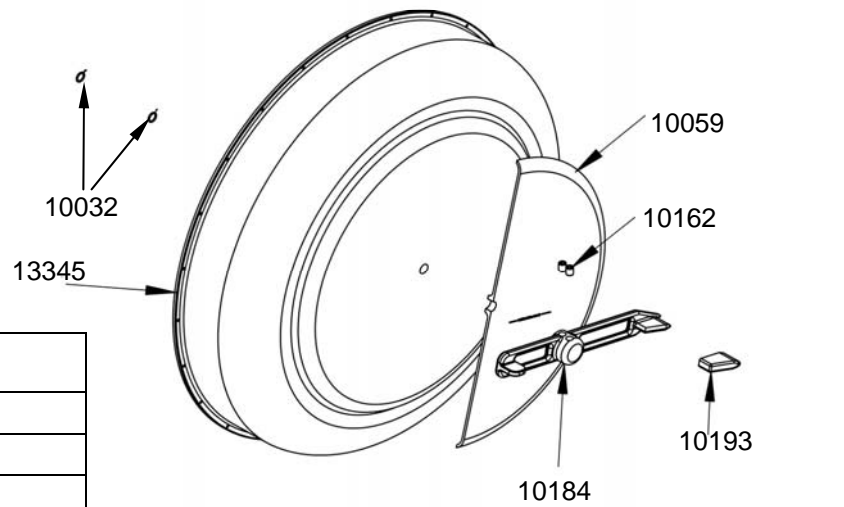
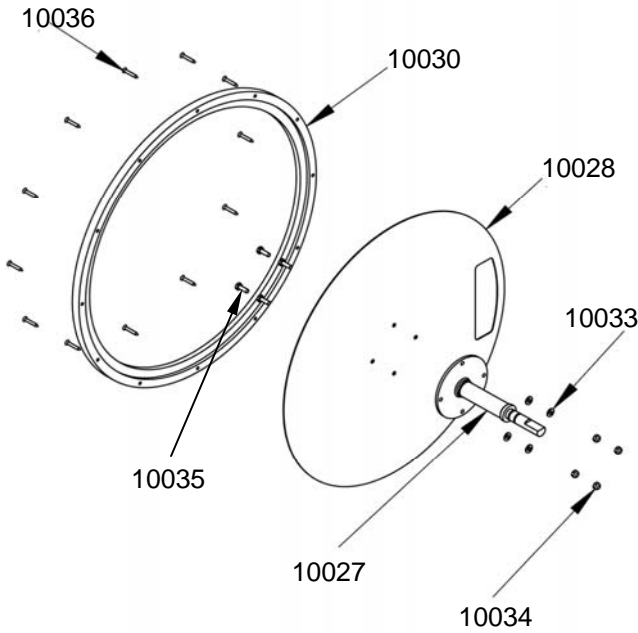

P/N	QTY	Description
10012	2	Bearing NSK6005ZZ
10017	1	Key way 7x7x32
10025	1	NBR 37x30x8t Flywheel Shaft Seal
10026	1	Small PK Transmission Pulley 50mm
10052	1	Grub Screw M4x6
10083	1	M10x20 Bolt
10138	1	Shaft Washer 30x10.2x3t Stainless Steel
10139	1	Spring Washer M10
10145	1	Bearing Spacer 30x25.1x20.5
10186	1	C Clip RTW-48
12300	1	SMC Tank Back—Gray

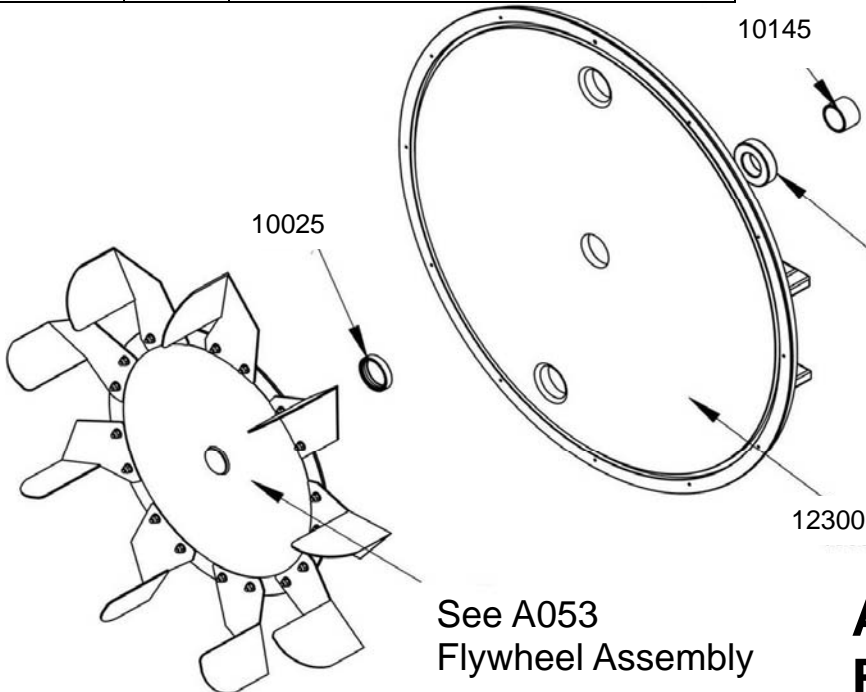
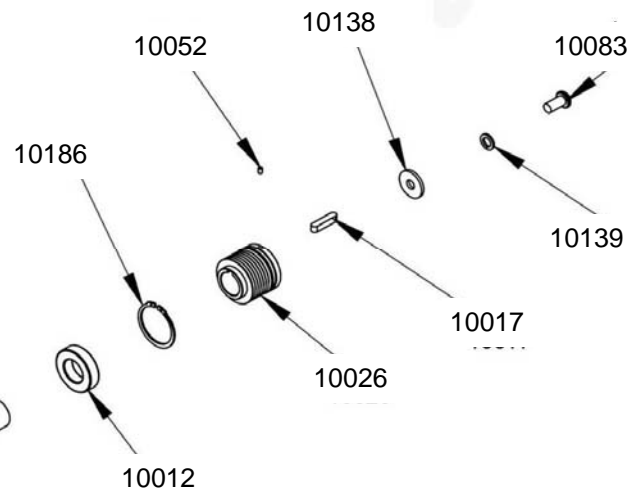

See A053
Flywheel Assembly

A054 Tank Back and Flywheel Assembly

FLUID CYCLE XT (XT-E720)

INTERNATIONAL WARRANTY – FULL COMMERCIAL USE

This product is designed and constructed for use in any Health Club / Fitness Studio application

First Degree Fitness Limited warrants that the **Fluid Cycle XT (model FR-E720)**, purchased from an authorised agent and in its undamaged original packaging, is free from defects in materials and workmanship. First Degree Fitness Limited or its agent will, at their discretion, repair or replace parts that become defective within the warranty period, subject to the specific inclusions and exclusions below.

Metal Frame – 10 Year Limited Warranty

First Degree Fitness will repair or replace the metal Main Frame should it fail due to any defect in materials or workmanship within 10 years of the original purchase. Warranty does not apply to frame coating.

Polycarbonate Tank & Seals – 3 Year Limited Warranty

First Degree Fitness will repair or replace the polycarbonate tank or seals should they fail due to any defect in materials or workmanship within 3 years of the original purchase.

Mechanical Components (of a non-wearing nature) – 2 Year Limited Warranty

First Degree Fitness will repair or replace any mechanical component should it fail due to any defect in materials or workmanship within 2 years of the original purchase.

All Other Components (of a wearing nature) – 1 Year Limited Warranty

First Degree Fitness will repair or replace any component should it fail due to any defect in materials or workmanship within 1 year of the original purchase.

Specific Inclusions

- Pedals & toe straps
- Hand grip assemblies
- Seat
- All rubber components
- Computer & speed sensor (excluding replaceable batteries)
- All drive belts & chains
- Crank arms
- All pulleys, rollers & bearings

General Exclusions

- Damage to the finish of any part of the machine
- Damage due to neglect, abuse, incorrect assembly or use of the machine
- Any charges for freight or customs clearance associated with the return or dispatch of parts
- Any damage to or loss of goods during transport of any kind
- Any labour cost associated with a warranty claim

General Conditions

- The serial number of the machine must be correctly registered with First Degree Fitness Limited or one of its appointed distributors
- First Degree Fitness Limited reserve the right to examine any part where replacement is claimed under warranty
- Warranty commences at time of sale but no later than six (6) months from date of original shipment
- Warranty period applies only to the original purchaser from the date of purchase and is not transferable
- The product must be returned to your place of purchase in original packaging with transportation, insurance and associated charges paid for by you and risk of loss or damage assumed by you
- First Degree Fitness makes no other warranties except as stated here and expressly disclaims all warranties not stated in this warranty. Neither First Degree Fitness nor its associates shall be responsible for incidental or consequential damages
- Manufacturer's warranty automatically commences upon sale of the product to end user or upon the expiration of one (1) year from month of manufacture, whichever occurs first