

Art.Nr. 3098006

SPEELTOREN MET DAK
TOURELLE AVEC TOIT
PLAYTOWER WITH ROOF
SPIELTURM MIT DACH
TORRE INCANTATA CON TETTO
LA TORRE DE JUEGOS
CON TECHO

Montagehandleiding
Notice de montage
Assembling manual
Montageanleitung
Instrucciones para el montaje
Istruzioni di installazione

Leeftijd:
Age: 6-14
Age group:
Alter:
Edad:
Età:

EUROPLAY nv
Eegene 9
B-9200 DENDERMONDE
tel. 32.52.22 66 22
fax.32.52.22 67 22
www.europlay.eu

Dat.: 20/08/2015

Page: 1/8

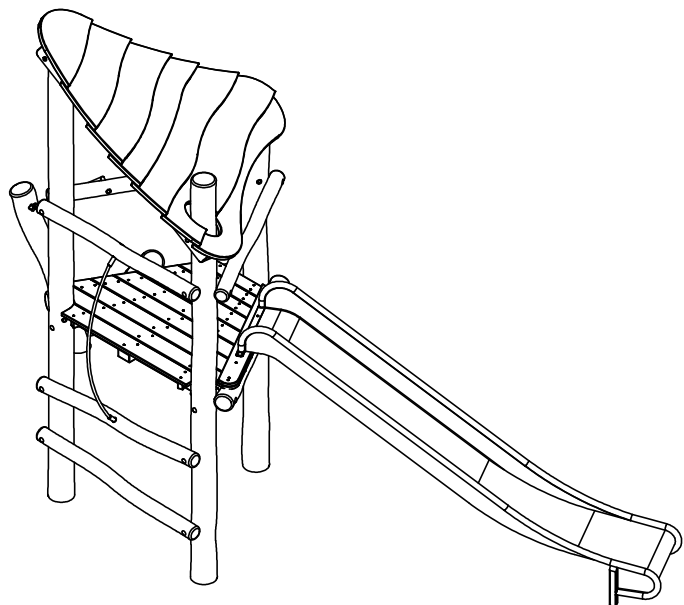

VALHOOGTE / HAUTEUR DE CHUTE /
FALL HEIGHT / FALLHÖHE/
ALTURA DE CAÍDA / ALTEZZA DI CADUTA

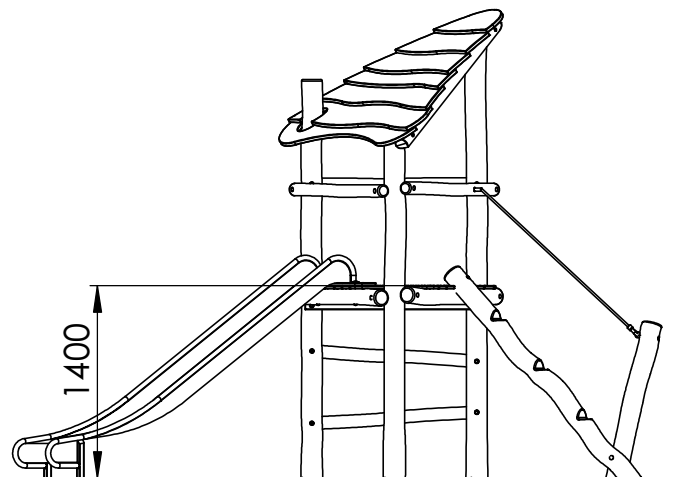

VEILIGHEIDSAFSTAND / ESPACE DE CHUTE / SAFETY AREA /
SICHERHEITSAFSTAND / ZONA DE SEGURIDAD / DISTANZA DI SICUREZZA

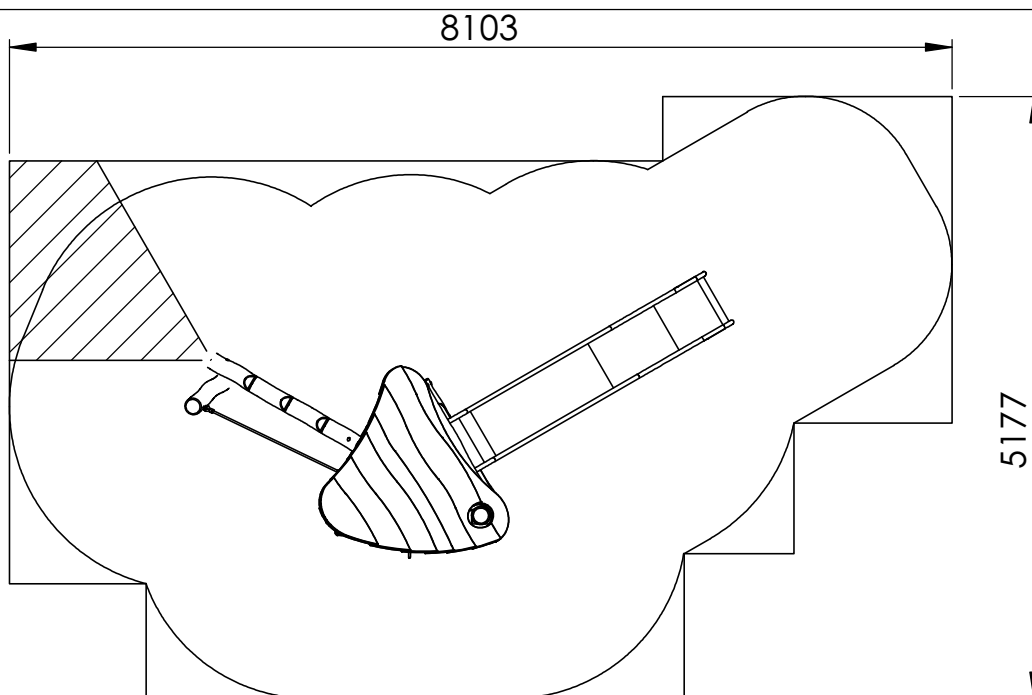



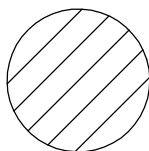



AFMETINGEN
DIMENSIONS
MASSE
DIMENSIONES
DIMENSIONI
L: 4,8m
H: 3,4m
Br: 2,5m

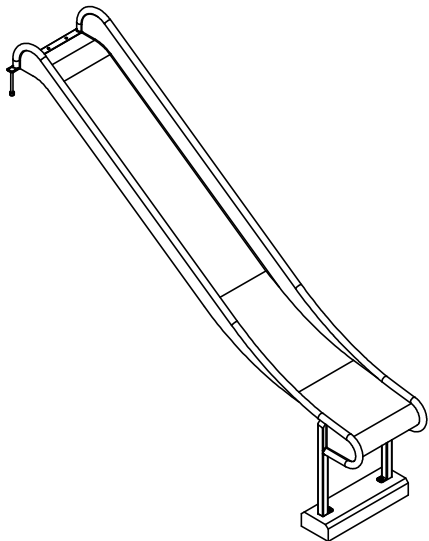
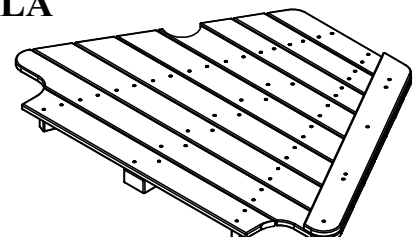
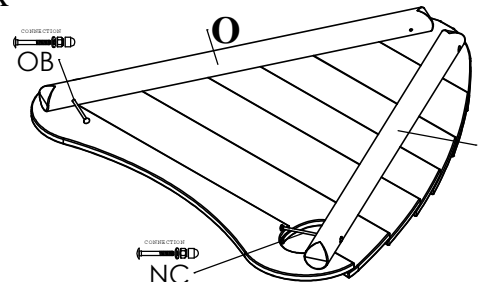
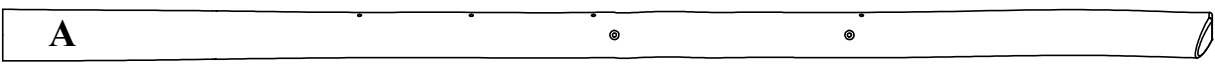
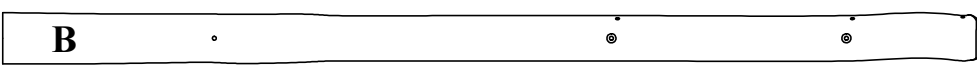

Samenvoegingszone RO691
Zone de liaison RO691
Verbindungsfeld RO691
Linking zone RO691
Zona de conexión RO691
Zona di allineamento RO691

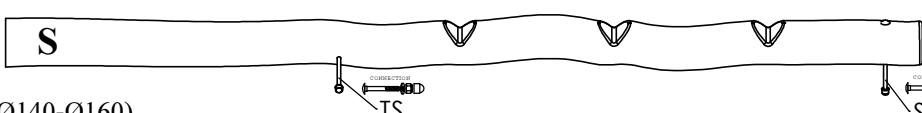
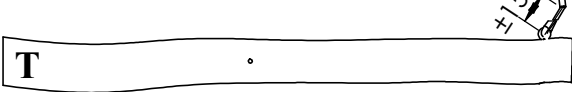
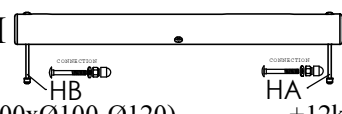
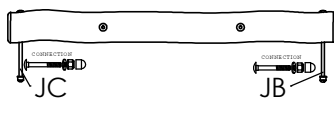
±33m²

Benodigdheden - Liste des pièces - Materials - Benötigtes - Accesorios - Requisiti

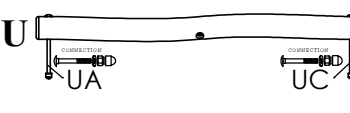
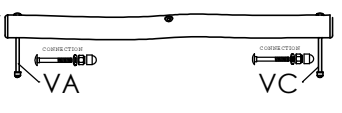
<p>1x</p>  <p>±60kg</p>	<p>1x VLA</p>  <p>±12kg</p>	
	<p>1x</p>  <p>±41kg</p>	
<p>1x</p>  <p>(4000xØ140-Ø160) ±61kg</p>		
<p>1x</p>  <p>(3230xØ140-Ø160) ±50kg</p>		
<p>1x</p>  <p>(3600xØ140-Ø160) ±55kg</p>		
<p>1x</p>  <p>(3000xØ140-Ø160) ±46kg</p>		
<p>1x</p>  <p>(1890xØ140-Ø160) ±29kg</p>	<p>1x</p>  <p>(1300xØ100-Ø120) ±12kg</p>	
<p>1x</p>  <p>(1300xØ100-Ø120) ±12kg</p>	<p>1x</p>  <p>(1300xØ100-Ø120)</p>	<p>1x</p>  <p>(1300xØ100-Ø120)</p>
<p>1x</p>  <p>(1300xØ100-Ø120)</p>	<p>1x</p>  <p>(1300xØ100-Ø120)</p>	<p>1x</p>  <p>(1300xØ100-Ø120)</p>

Benodigdheden - Liste des pièces - Materials - Benötigtes - Accesorios - Requisiti

<p>1x</p> <p style="text-align: center;">±1273</p>	<p>1x</p> <p style="text-align: right;">(1300x95x45)</p>
--	--

<p>2x</p> <p>M10x150</p>	<p>2x</p> <p>M10</p>	<p>18x</p> <p>6x</p> <p>4,5x50</p> <p>4,5x70</p>
--------------------------	----------------------	--

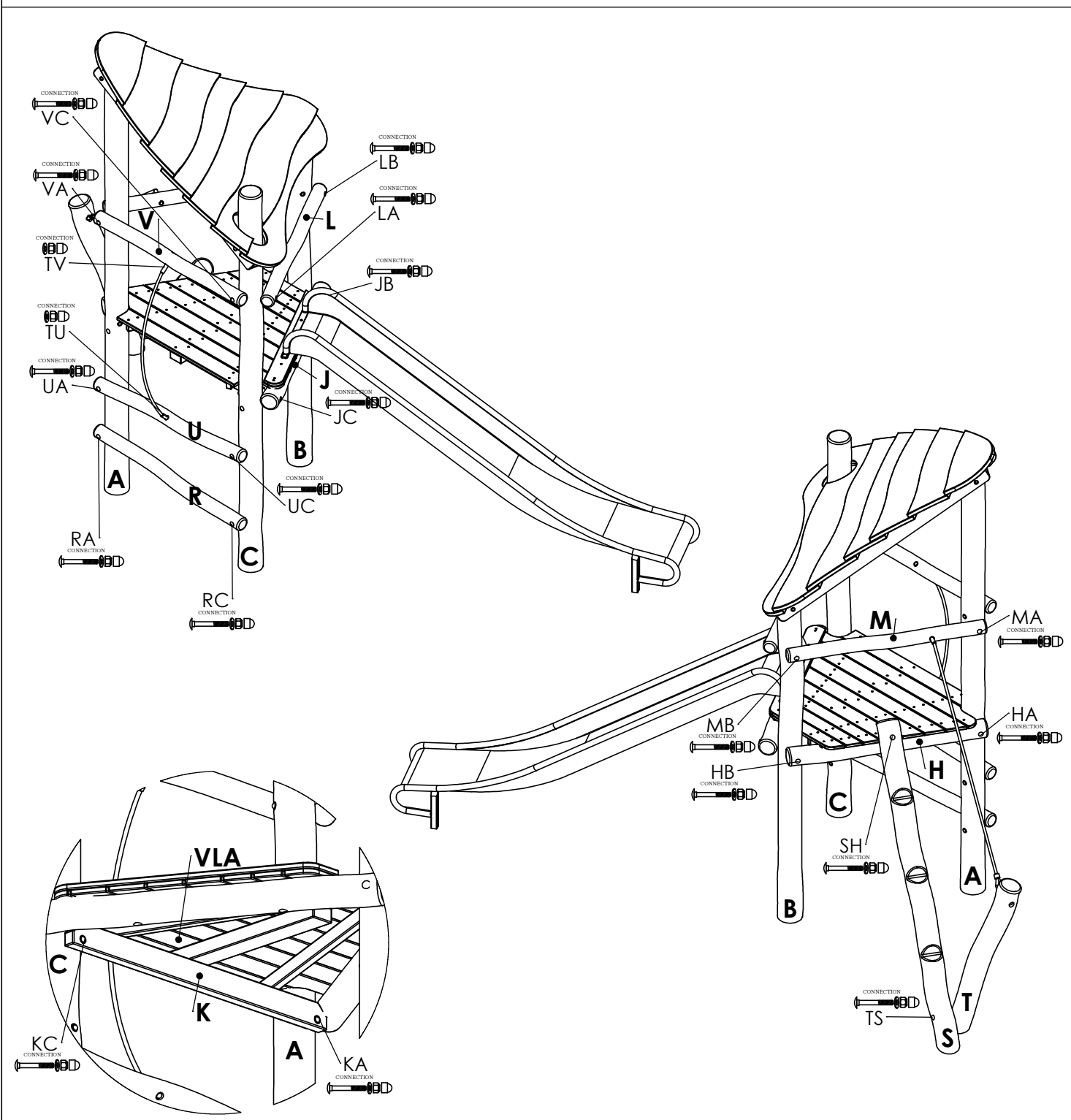

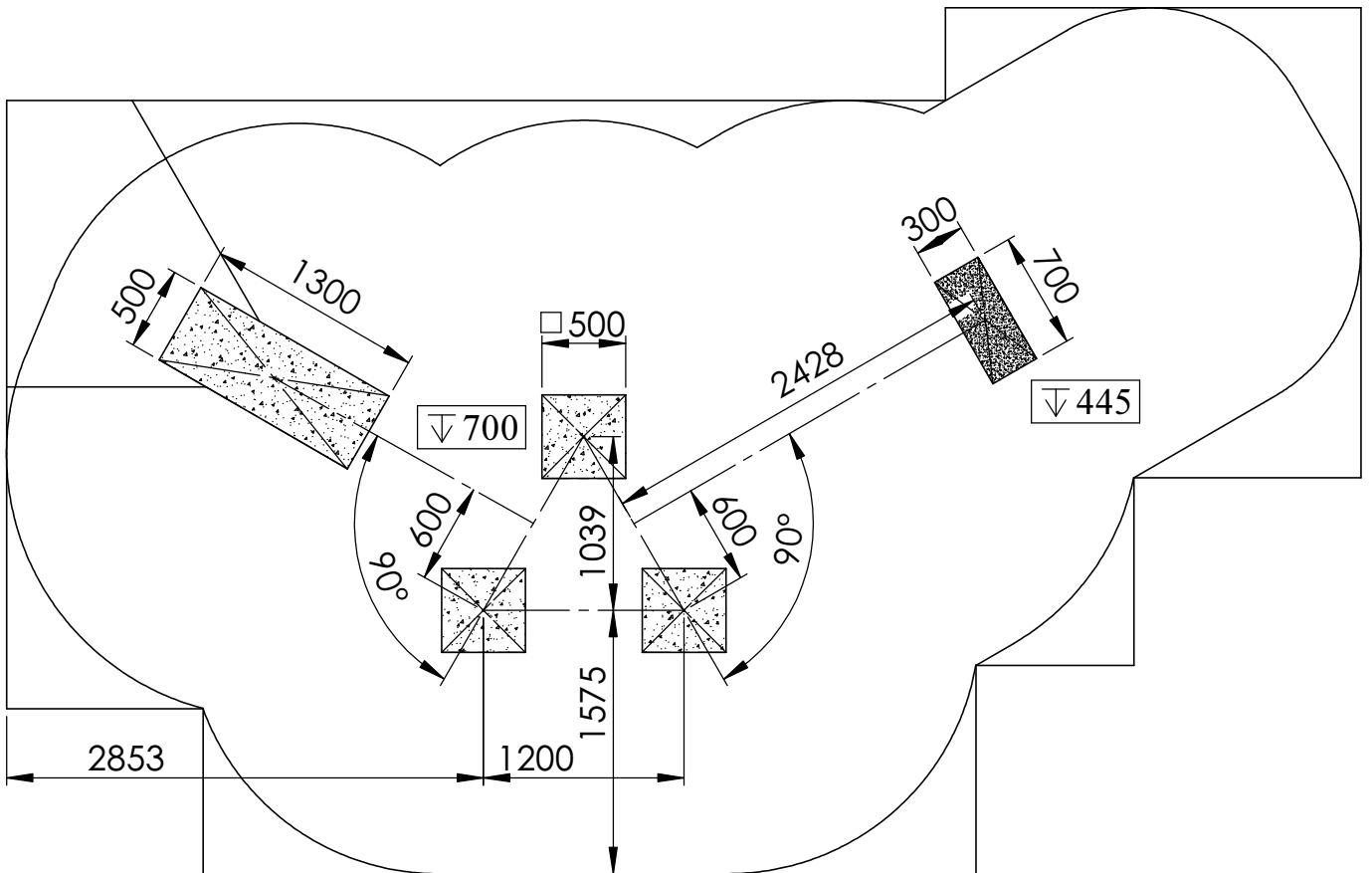
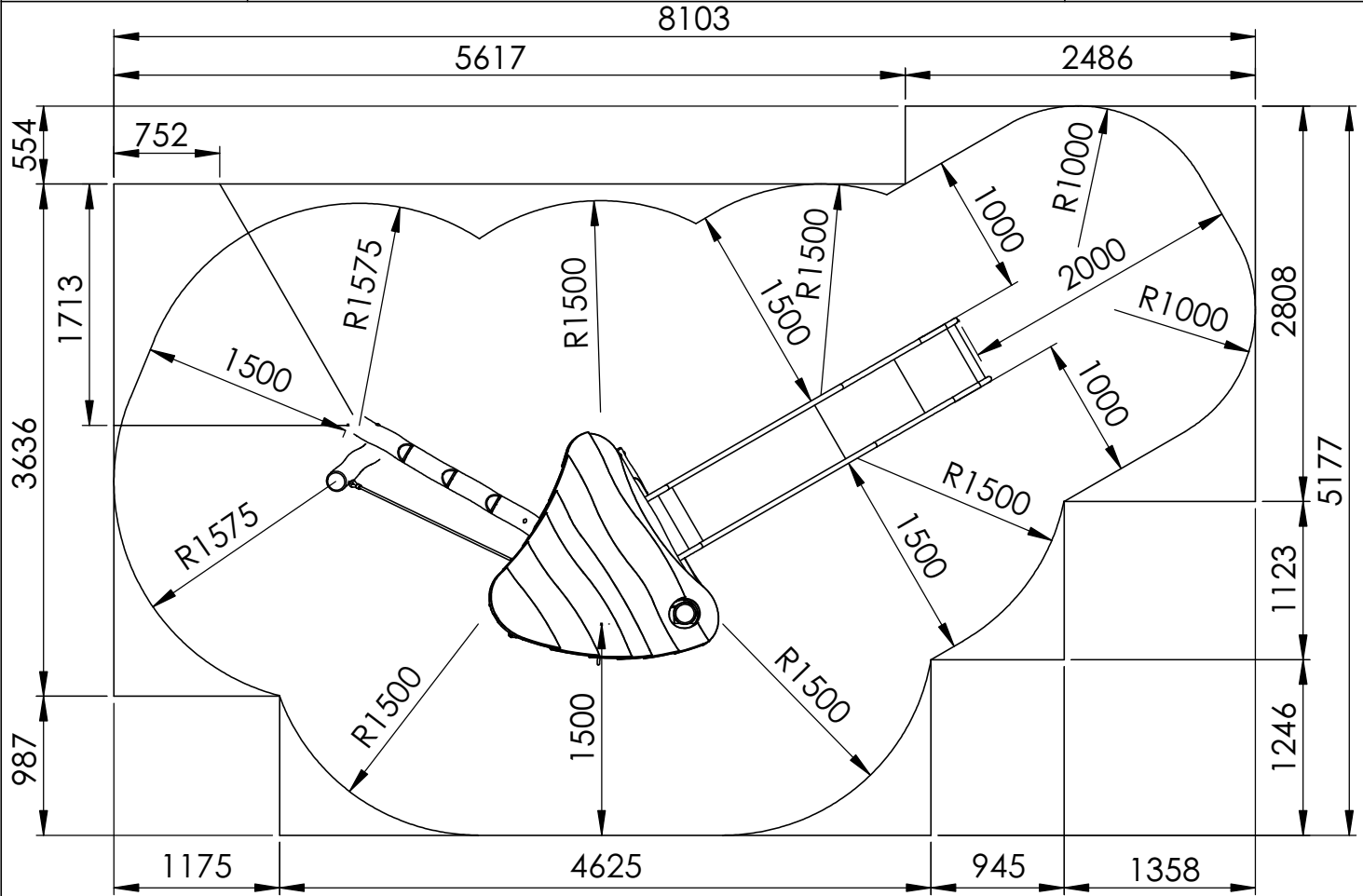

1

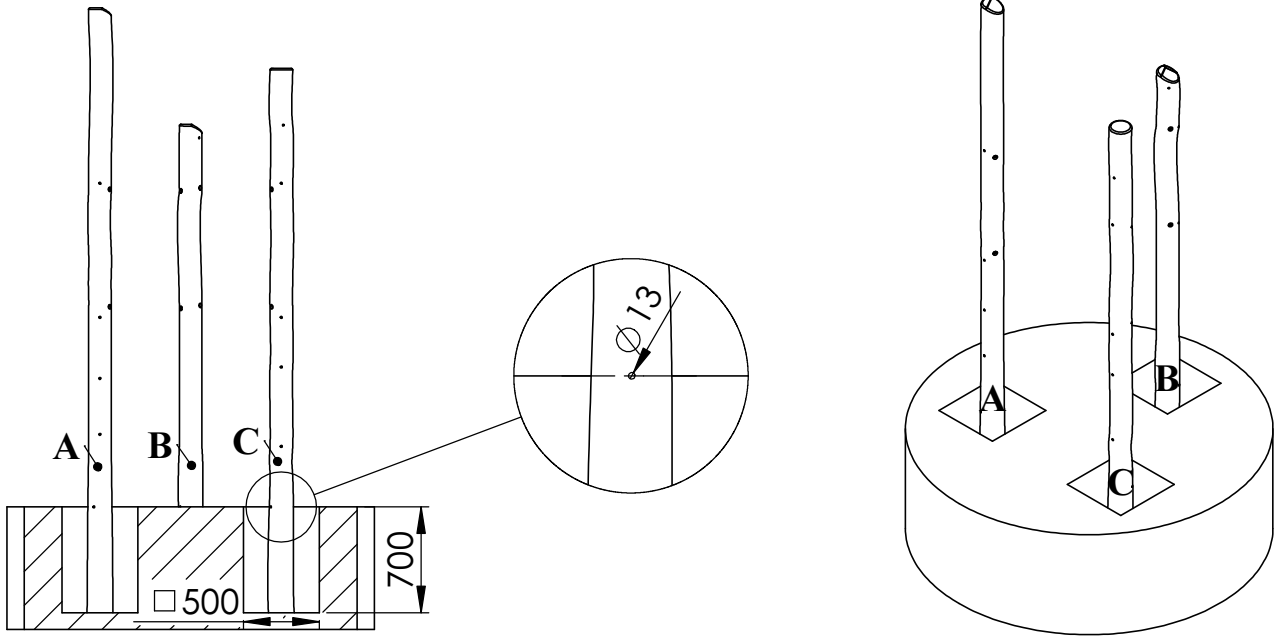

2

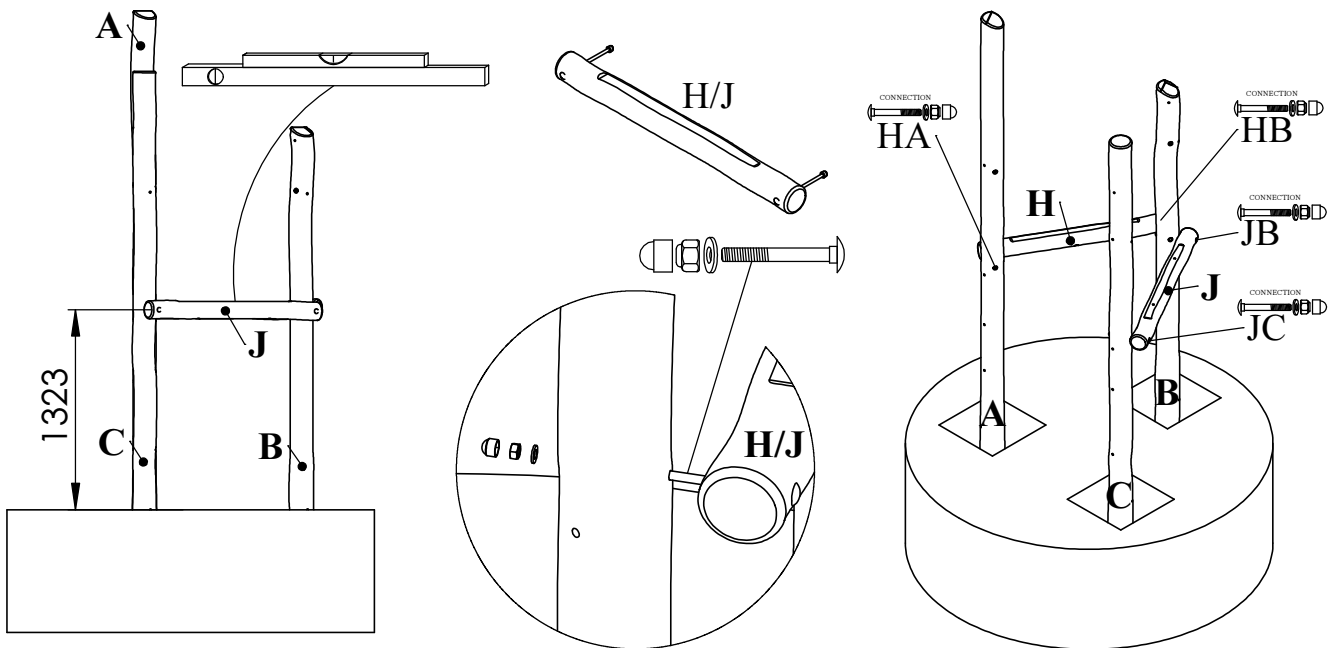

3

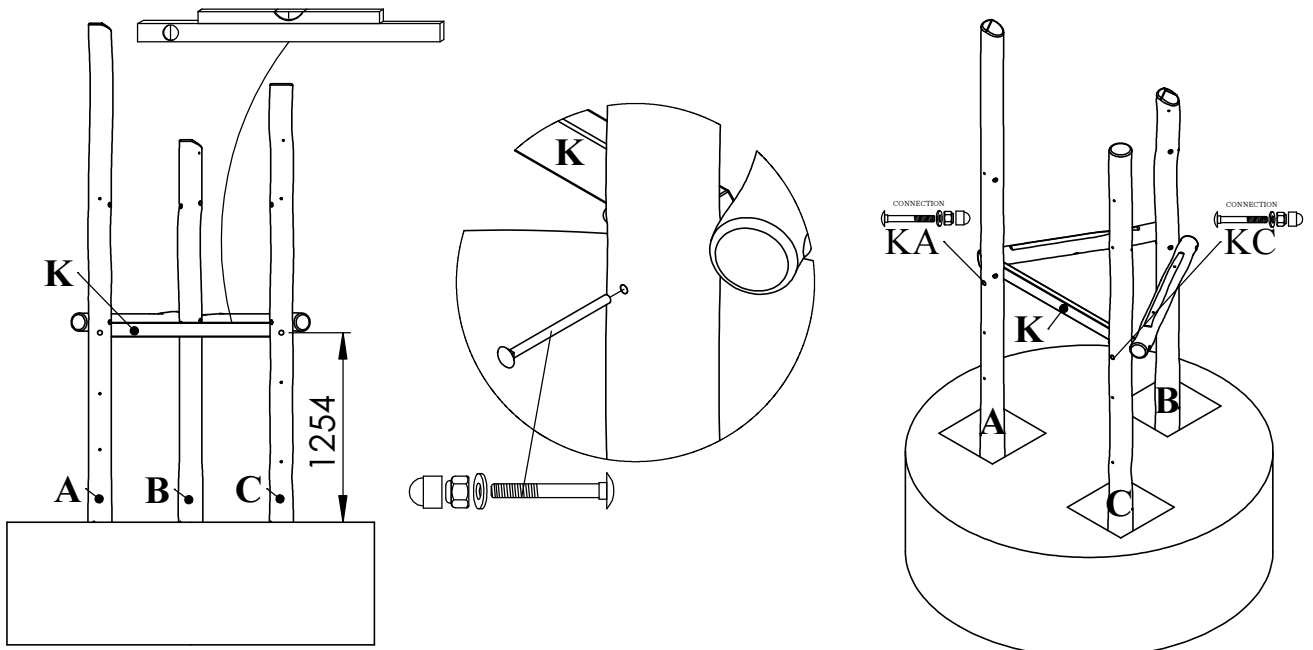

4

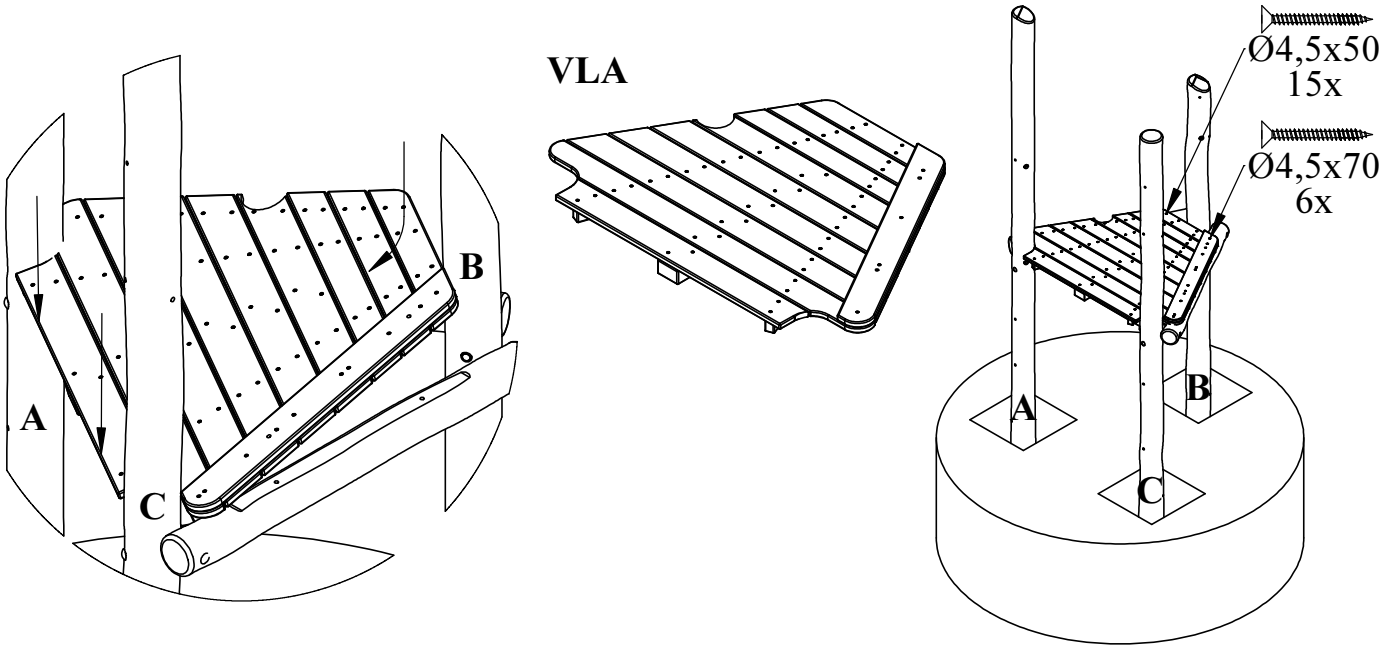

5

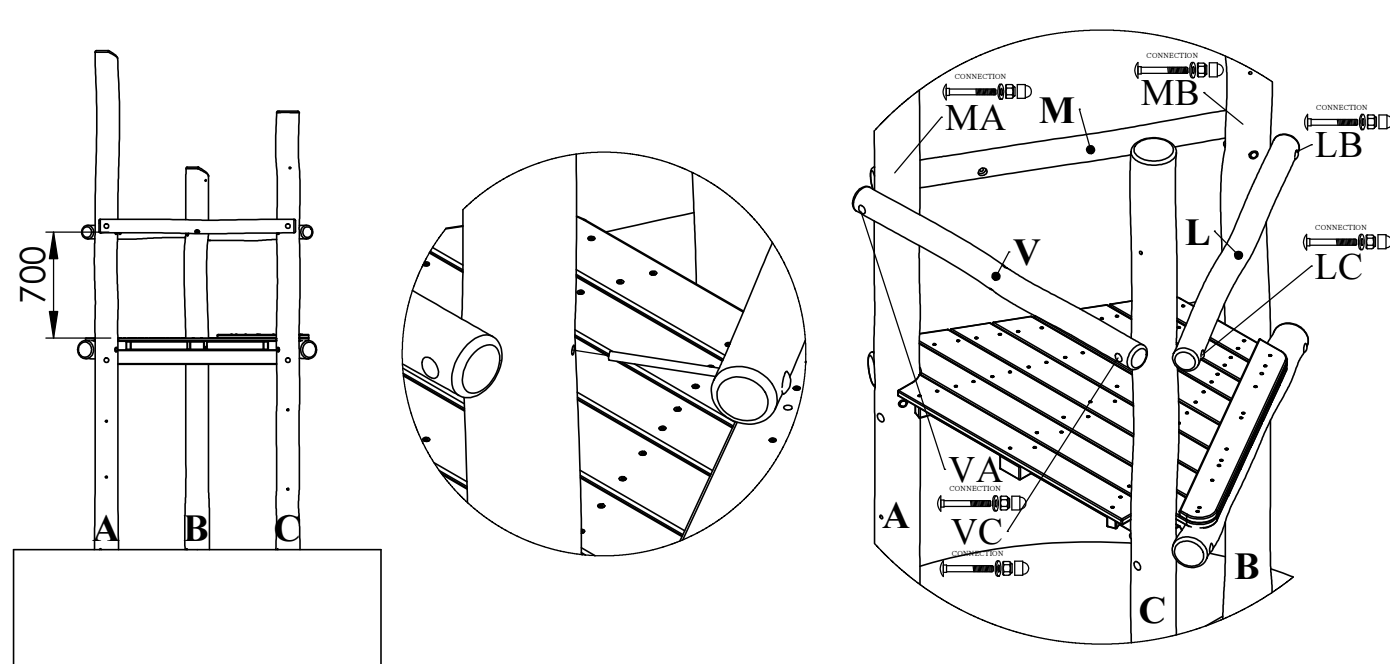

6

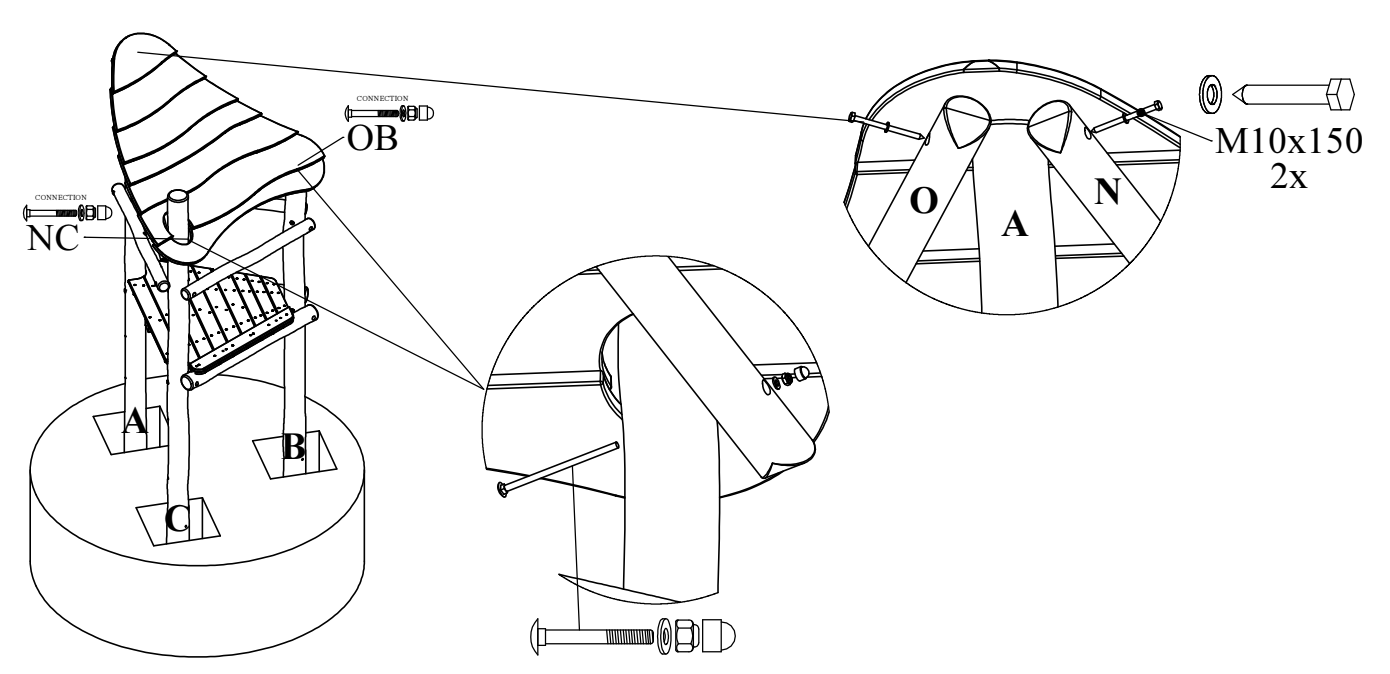

7

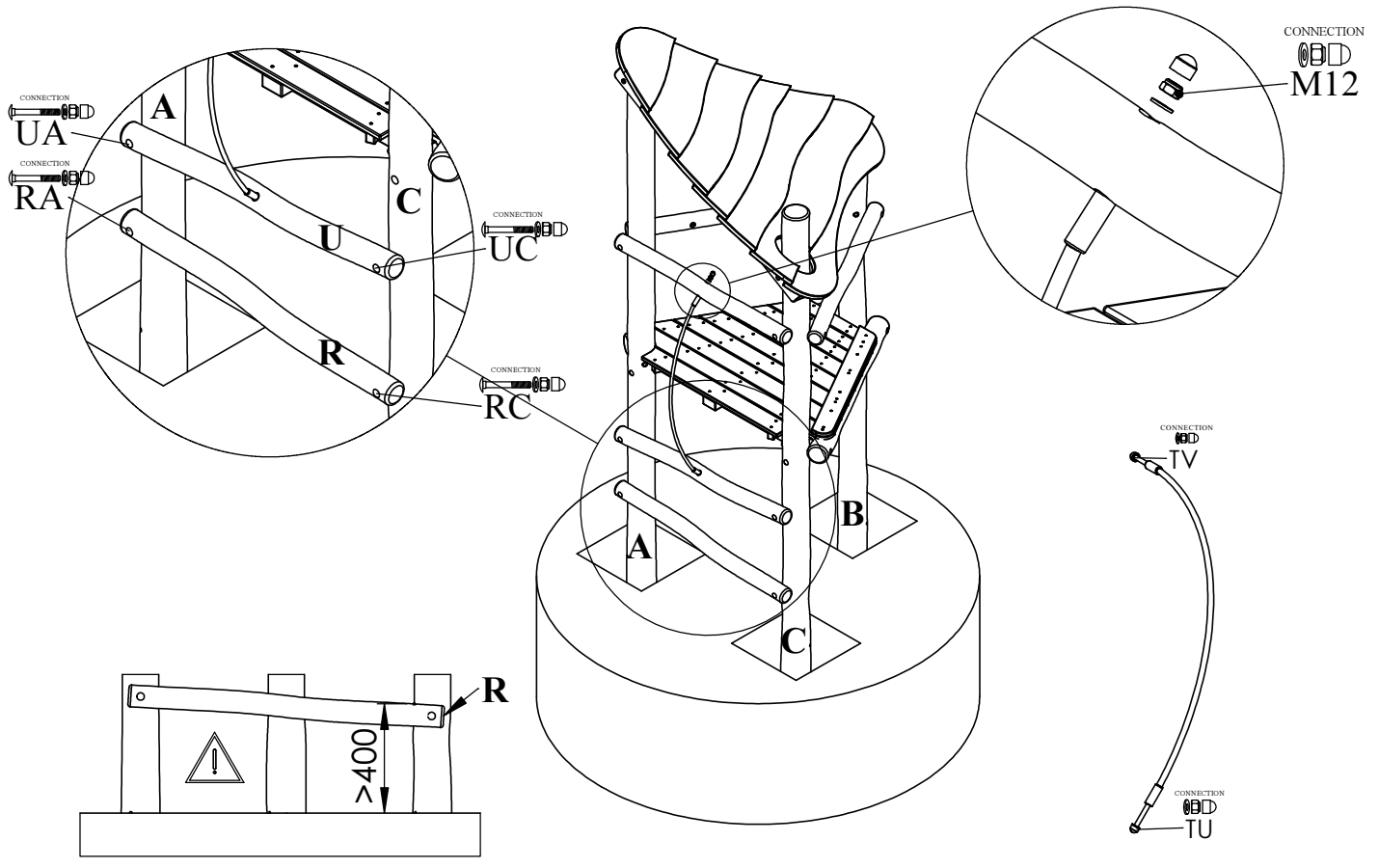

8

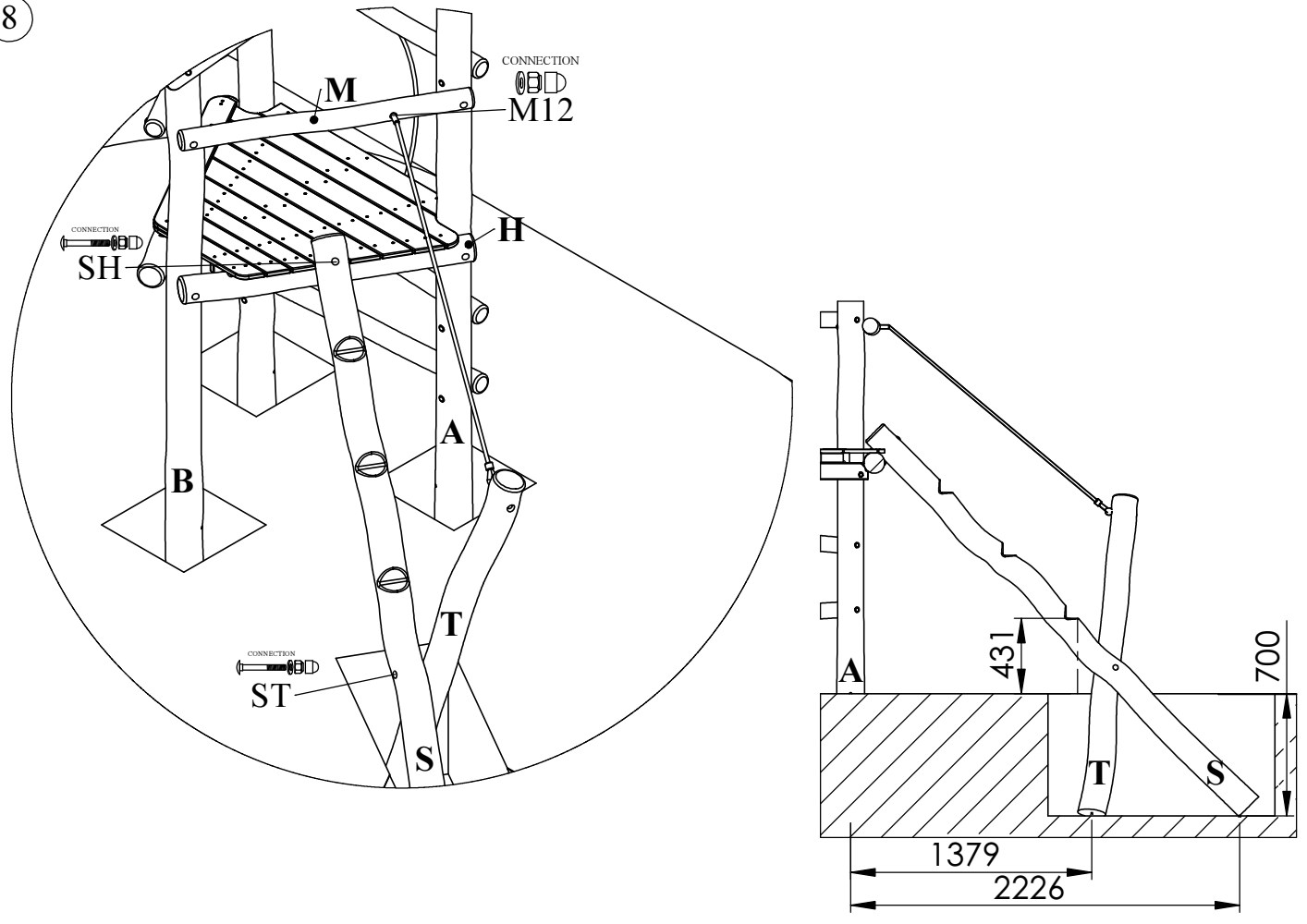

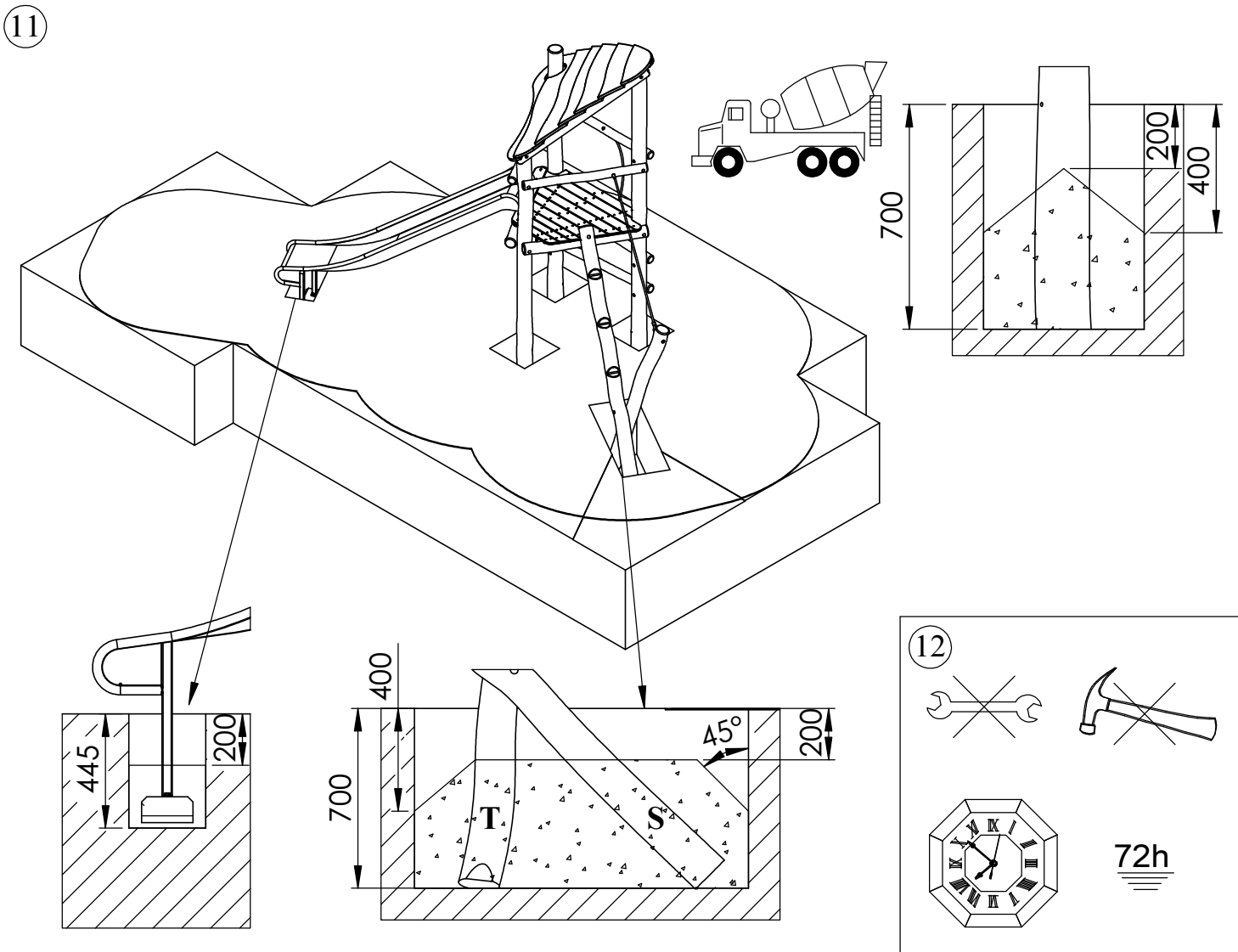
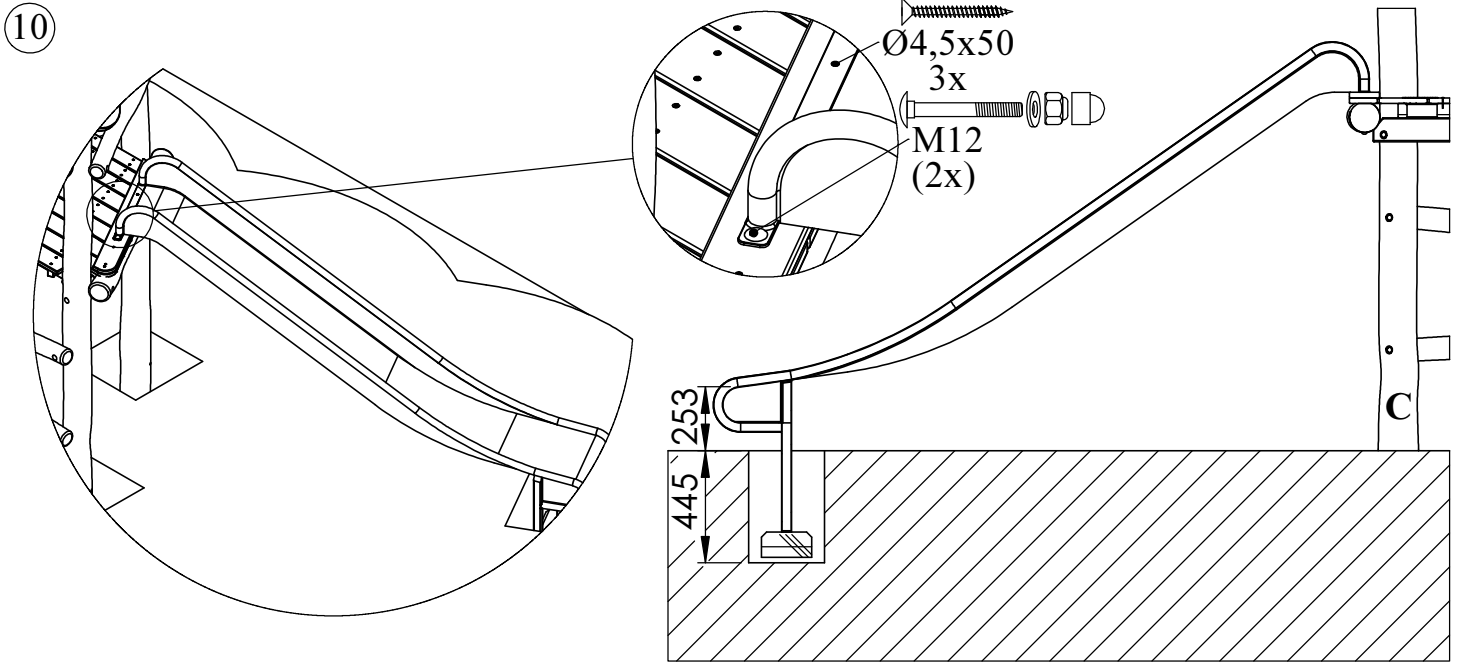

Bij droog weer moeten alle bouten en schroeven opnieuw aangespannen worden.
 Par temps sec il faut resserrer régulièrement toute la visserie.

By dry and warm weather check the tightness of all bolts and screws.

Bei trockenem Wetter müssen alle Schrauben und Bolzen aufs neue angespannt werden.

Para el tiempo seco, se necesita cerrar o ajustar los tornillos y tuercas.

Con tempo asciutto, tutti i bulloni e le viti devono essere avvitate nuovamente.

13